

## A Cube corner reflector Interferometer Configurations

Corner reflector interferometers are the most simple interferometer configurations. Those used for distance, speed and acceleration measurement consist of the following optical components (Fig. 1):

- |   |                        |
|---|------------------------|
| <b>1 Polarizing beam splitter 101</b>       | <b>269302-4010.124</b> |
| <b>1 Corner reflector 102 (reference)</b>   | <b>269302-4010.224</b> |
| <b>1 Corner reflector 102 (measurement)</b> | <b>269302-4010.224</b> |

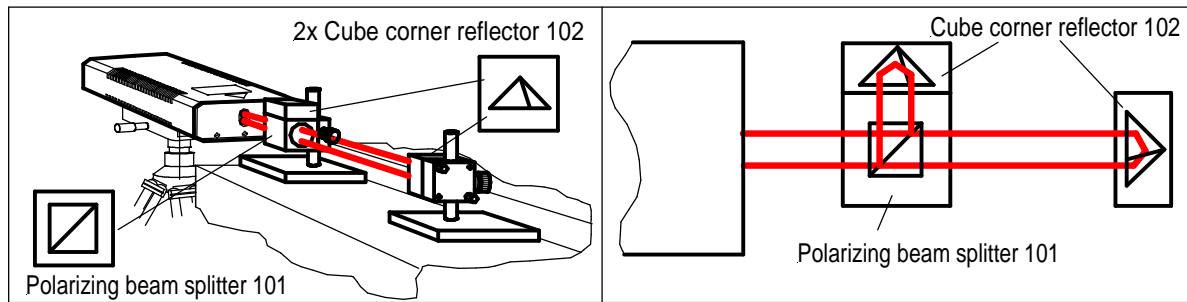


Fig. 1: Corner Reflector Interferometer (optical arrangement)

### Functional description

The light emerging from the laser head serves as the measurement beam, which passes an interferometer arrangement followed by a measuring and a reference reflector, and strikes a detector E1. Because of a polarizing beam splitter in the interferometer, the measuring reflector only receives light of frequency  $f_1$ , while the reference reflector only receives light of frequency  $f_2$ . With the measuring reflector at rest, E1 detects the laser's differential frequency ( $f_1 - f_2 = 640$  MHz), which is equal to the electronic reference signal (E2) detected in the laser head. As the measuring reflector is displaced, the beam portion of frequency  $f_1$ , reflected by this reflector, is Doppler-shifted by  $\pm df_1$ . Accordingly, detector E1 registers a measuring frequency of  $\Delta f + df_1$  or  $\Delta f - df_1$ , depending on which way the measuring reflector is moved. The two signals detected (E1 and E2) are compared with each other in the high-frequency section of the laser interferometer system. The result obtained is the frequency shift  $\pm df_1$  due to the Doppler effect; this shift is a measure of the path of the measuring reflector, from which the displacement of the measuring reflector is counted (Fig. 2).

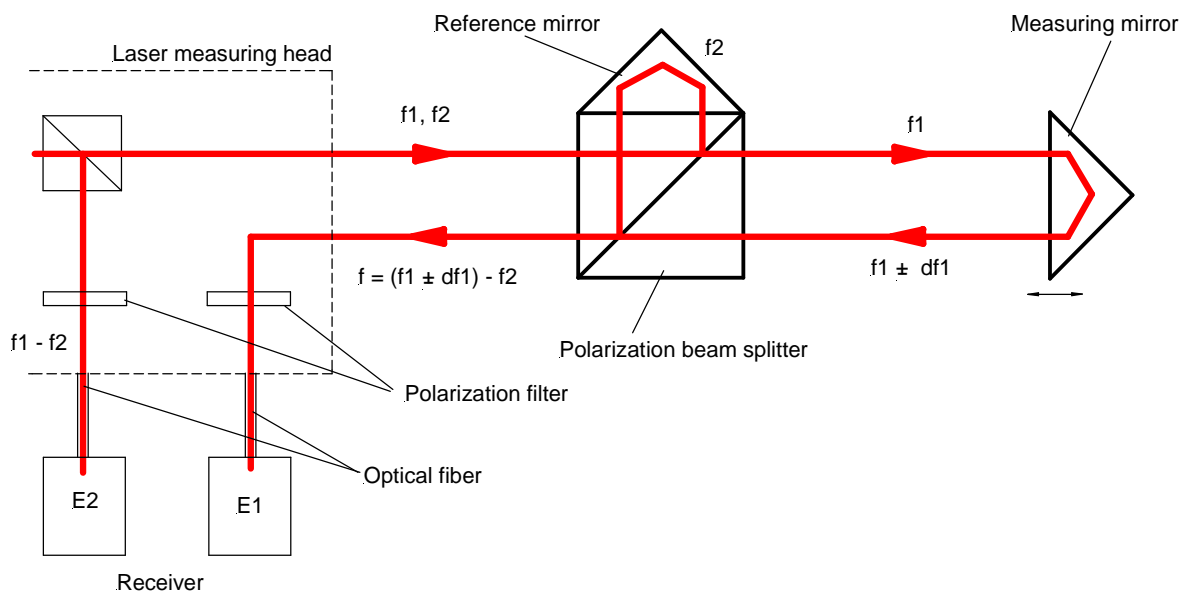
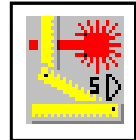


Fig. 2: Cube corner reflector interferometer (operating principle)



## Assembly

Fig. 3 shows the optical and mechanical modules and components that make up a 2.5nm-resolution corner reflector interferometer. Fig. 1 presents the overall configuration of the functional system (the tripod and the adjustable table are not shown). Fig. 4 depicts the assembly of the modules and components, and Fig. 5 illustrates a practical application at a machine tool. Thanks to the system's modular design, other setups are also possible. For the contents of the carrying cases and the placement of the components therein, see Fig. 7 in section " Assembly of Modules and Components ".

## Cube corner reflector interferometer (distance measurement, 2.5 nm resolution)

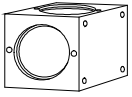
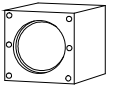
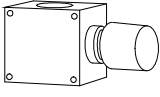

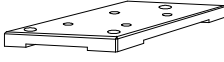



<p><b>Polarizing beam splitter 101</b> 269302-4010.124</p>		<p>Quantity: 1</p>
<p><b>Corner reflector 102</b> 269302-4010.224</p>		<p>Quantity: 2</p>
<p><b>Clamping fixture 507</b> 269302-4010.325</p>		<p>Quantity: 2</p>
<p><b>Beam stop plate 516</b> 269302-4014.210</p>		<p>Quantity: 2</p>
<p><b>Mounting plate 504</b> 269302-4014.410</p>		<p>Quantity: 2</p>
<p><b>Magnetic base 506</b> 260298-3000.128</p>		<p>Quantity: 2</p>
<p><b>Column pin 140</b> 260297-9900.128</p>		<p>Quantity: 2</p>
<p><b>Set of screws</b> 269302-4005.624</p>		<p>Quantity: 1</p>

Fig. 3: Optical and mechanical components of the Corner Reflector Interferometer

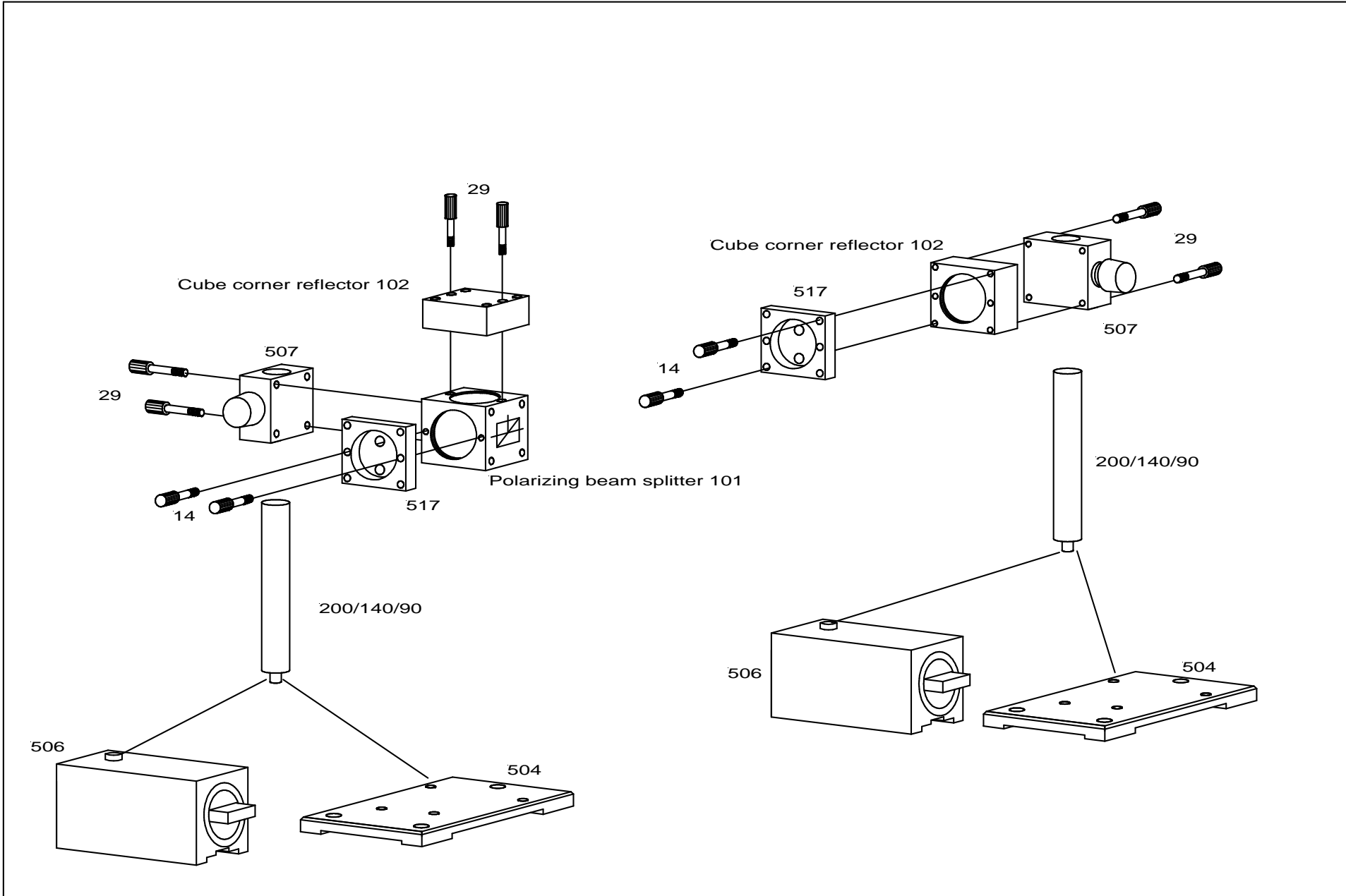


Fig. 4: Assembly of the modules and components

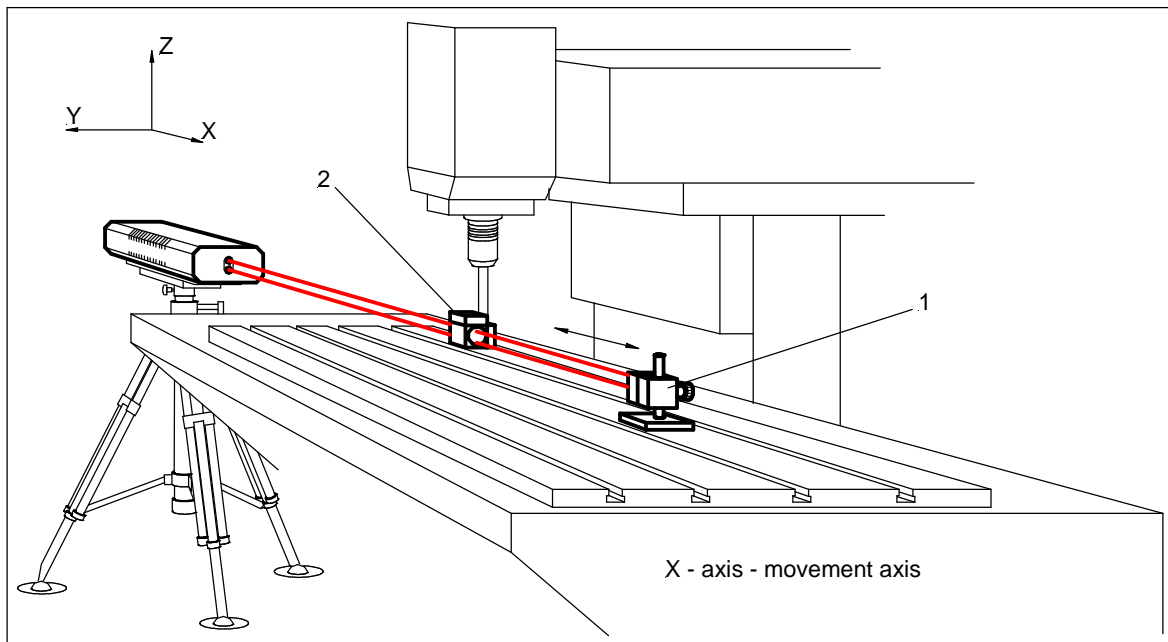
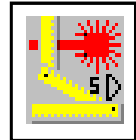


Fig. 5: Measurement setup at a machine tool

### Measurement assembly

With all modules and components assembled, the configuration consisting of **laser head, interferometer and cube corner reflector** can be set up on the object to be measured. The setting-up procedure should follow the sequence of steps described below:

1. Identify the axis of motion to be measured and find a location on the moving part of the object where the optical system can be fixed (1).
2. Find a stationary reference point in line with the axis of movement (2).



#### IMPORTANT:

The optical modules must be so located that the point of location on the motion axis, the stationary reference point of fixing the interferometer and the beam exit port of the laser head can be aligned on a line in parallel with the motion axis (Fig. 6).

3. Fix the optical modules at the locating points found, wherever possible, in order to reduce measurement errors:
 

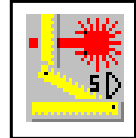
Interferometer	stationary reference point (2)
Cube corner (measuring) reflector	movable reference point (1)



#### IMPORTANT:

Interferometer and corner reflector must have equal distances to the measuring line ( $h_1 = h_2$  in Fig. 6) in order to avoid angular errors.

4. Roughly align the laser beam with the optical axis of the installed optical modules.



**Tips:**

- (1) Position the laser head as closely as possible to the interferometer.
- (2) Position the corner reflector at the most distant point possible from the interferometer.
- (3) Check whether the adjustable table is at the centre of its parallel displacement and tilting ranges. ⇒ This is important to ensure sufficient freedom of adjustment both ways during fine alignment of the beam path.

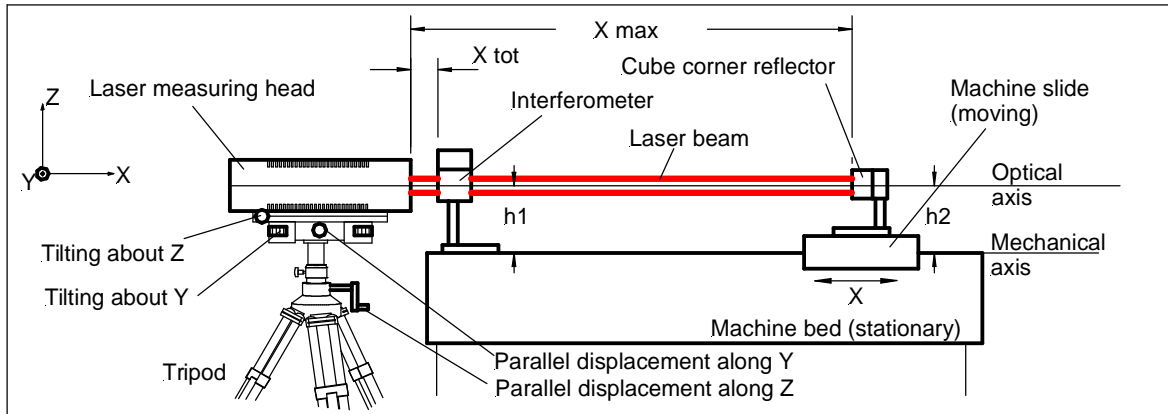


Fig. 6: Measuring setup, optical path

5. Fine alignment of the beam path



**Tip:**

To facilitate the alignment of the optical path in parallel with the measuring axis, remove the interferometer from the beam path, leaving only the corner reflector. ⇒ That way, only one beam returns to the laser head, which makes it easier to assess the state of alignment.

A fundamental distinction is made (Fig. 7) between

- positional alignment (parallel displacement along y and z) ( $\Delta y, \Delta z$ )
- directional alignment (tilting about y and z) ( $\Delta\phi_y, \Delta\phi_z$ )

The ZLM 700 is designed so that both adjustment facilities are provided on the adjustable table / tripod assembly. The merit of this arrangement is that you do not have to constantly alternate between two adjusting locations (laser head - measuring reflector).

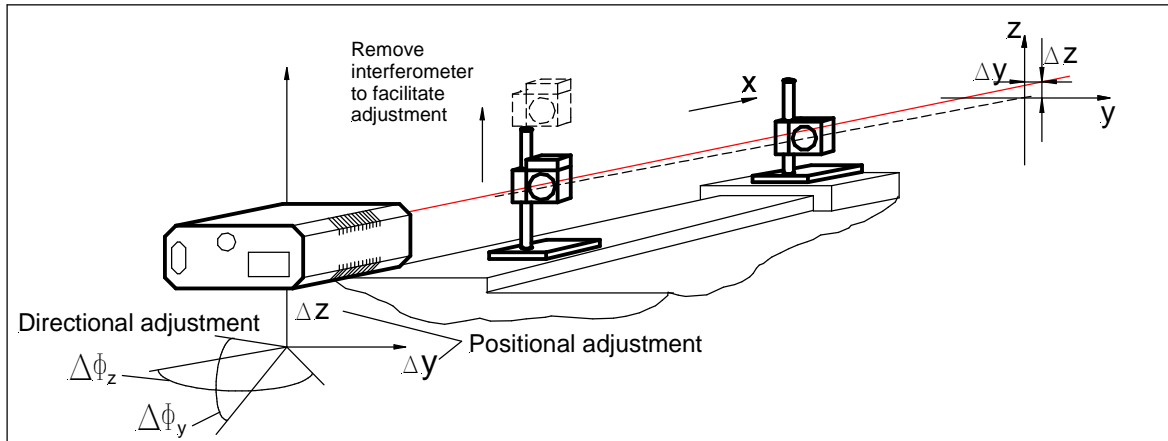
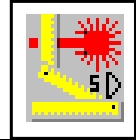


Fig. 7: Alignment of the beam path

The location of the cube corner reflector relative to the interferometer is important for both positional and directional alignment (Fig. 8):

Positional alignment, Parallel displacement  $\Rightarrow$  at the cube corner reflector position nearest to the laser

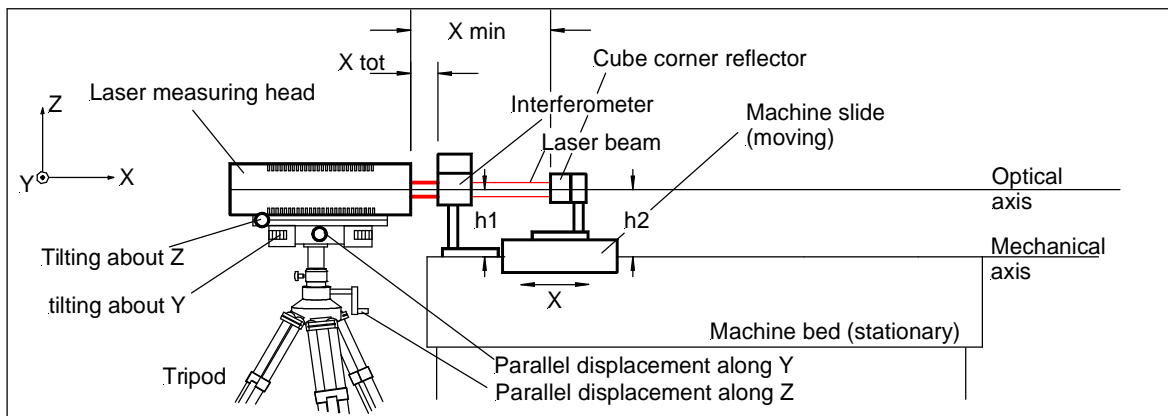


Fig. 8: Positional alignment of the beam path

Directional alignment, tilting  $\Rightarrow$  at the corner reflector position most distant from the laser head

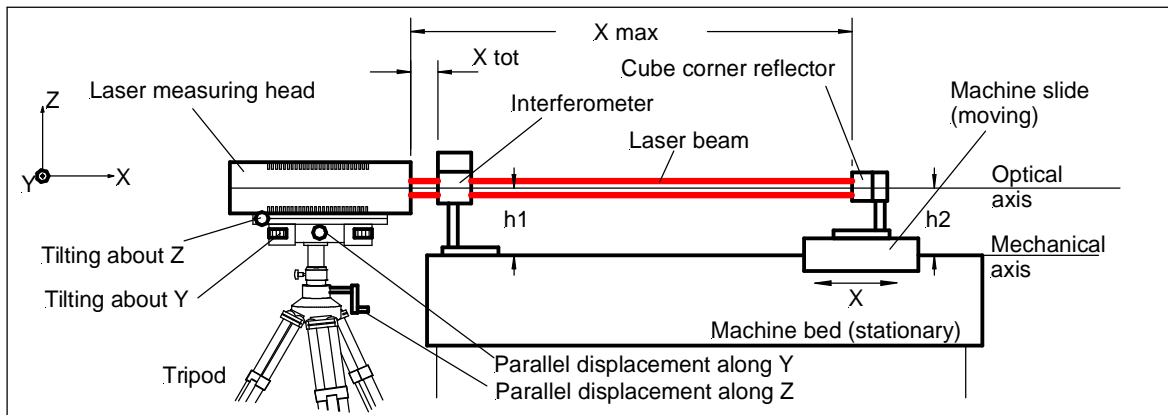
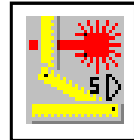



Fig. 9: Directional alignment of the beam path



## Adjustment

From these basic principles, the following procedure of aligning the beam path results:



- 1) Select menu item  in the "Measurement" program routine.  
In this menu item, the powers of the two beams reflected back into the laser head (reference and measuring beams) are represented by two spots on the monitor screen. The screen graph immediately shows the effect of alignment manipulations and thus allows the quality of alignment of the two beams to be checked and optimized.
- 2) Move cube corner reflector to the point most distant from the laser head and fix it there (Fig. 9).  
Adjust the laser beam direction in y and z:  
 $\Delta\Phi_y$  - Turn the two lateral knurled screws of the adjustable table;  
 $\Delta\Phi_z$  - Turn the two knurled height adjustment screws of the adjustable table.

Align until the reflected beam hits the beam entrance port of the laser head.  
For fine alignment, use the cross-lines shown on the screen.

- 3) Move cube corner reflector to the point closest to the laser and fix it there (Fig. 8).  
Adjust the laser position in y and z:  
 $\Delta y$  - Turn the micrometer screw of the adjustable table to displace the laser in parallel.  
 $\Delta z$  - Turn the height adjustment handwheel of the tripod.

Align until the reflected beam hits the beam entrance port of the laser head.  
For fine alignment, use the cross-lines shown on the screen.

Repeat steps 2 and 3 alternately until no significant change in beam position (relative to the screen cross-lines) can be noticed.

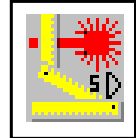
The permanent angular error between the optical and mechanical axes can be seen as the blue moving bar below the cross-lines presentation.



### **IMPORTANT:**

Pay attention to the same local situation of the points of measuring and reference beam in the cross-lines.  
(importantly for perfect interferenc signal)

Aligning the interferometer completes the alignment of the setup, which is now ready for measurement (see the Software Manual).



## Extension of the measuring construction for the diagonal measurements

The measuring construction described in the previous section is suitable for the orthogonal measurement of axes to machine tools, coordinate measuring machines, Industrial roboter and so on.

This means that the measurings of the coordinate axes (X -, Y - and Z - axis) are made separately and independently of each other.

For measuring diagonal movements (consists of simultaneous x-, y- and z-movings) the extension kit named “**Diagonal measurement**” is needed.

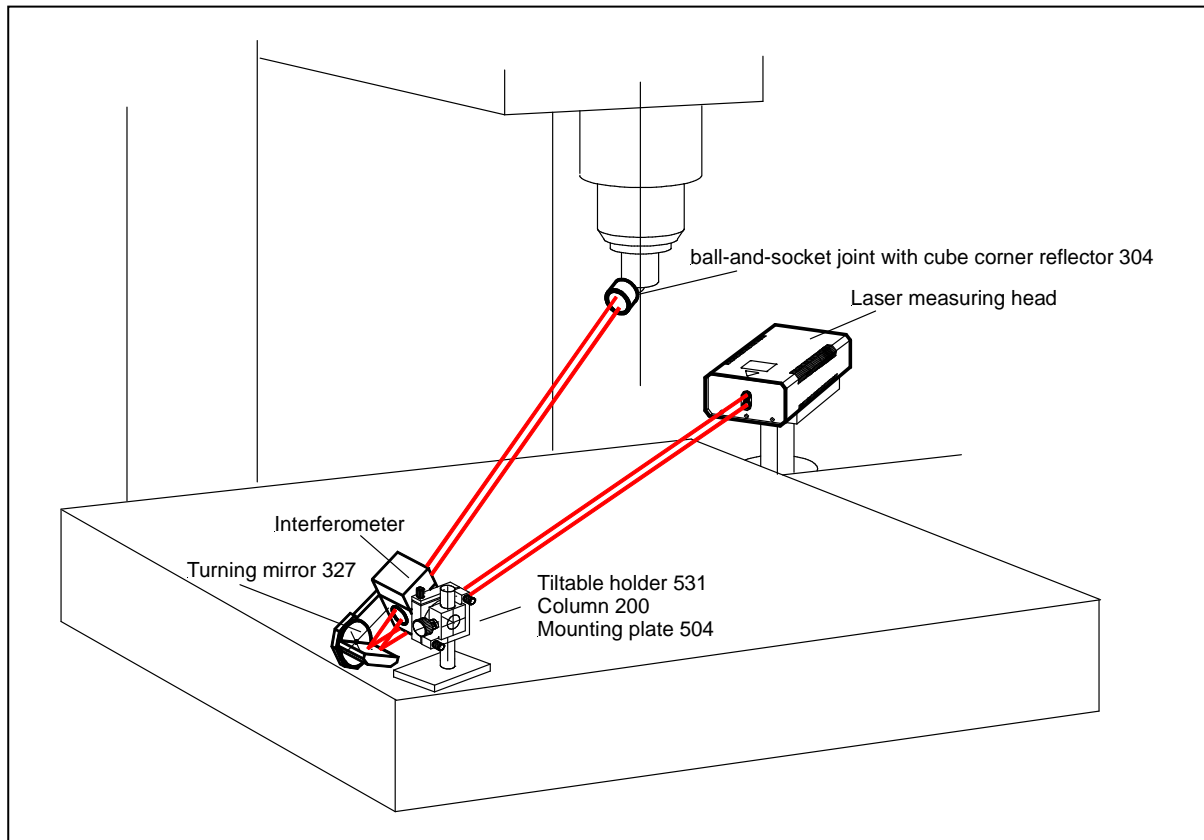


Fig. 10: Optical setup for diagonal measurement at a machine

By the tiltable holder 531 the interferometer can be taken to the diagonal direction of axis.

The cube corner reflector is swung in the direction by a ball-and-socket joint.

The cone (d<sub>mr</sub> 15) of the ball-and-socket joint can be put in to the toolhead of the machine without problems.

The interferometer is completed with the tiltable mirror 327. Thereby the laser measuring head can keep its horizontal position during the diagonal measurements.

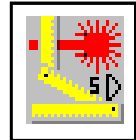


Fig. 11 shows the optical and mechanical modules and components of the extension kit for diagonal measurement

**Extension kit for diagonal measurement**

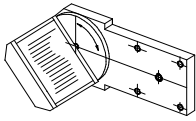

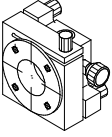
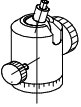
<p><b>Turning mirror 327</b> 269302-4013.724</p>		<p>Quantity: 1</p>
<p><b>Cube corner reflector 304</b> 269302-4059.124</p>		<p>Quantity: 1</p>
<p><b>Tilttable holder 531</b> 269302-40.725</p>		<p>Quantity: 1</p>
<p><b>Ball-and-socket joint</b> 260297-9900.628</p>		<p>Quantity: 1</p>

Fig. 11: Optical and mechanical modules and components

The assembly of the optical components, the mechanical mounting and adjusting elements is illustrated into Fig. 12.

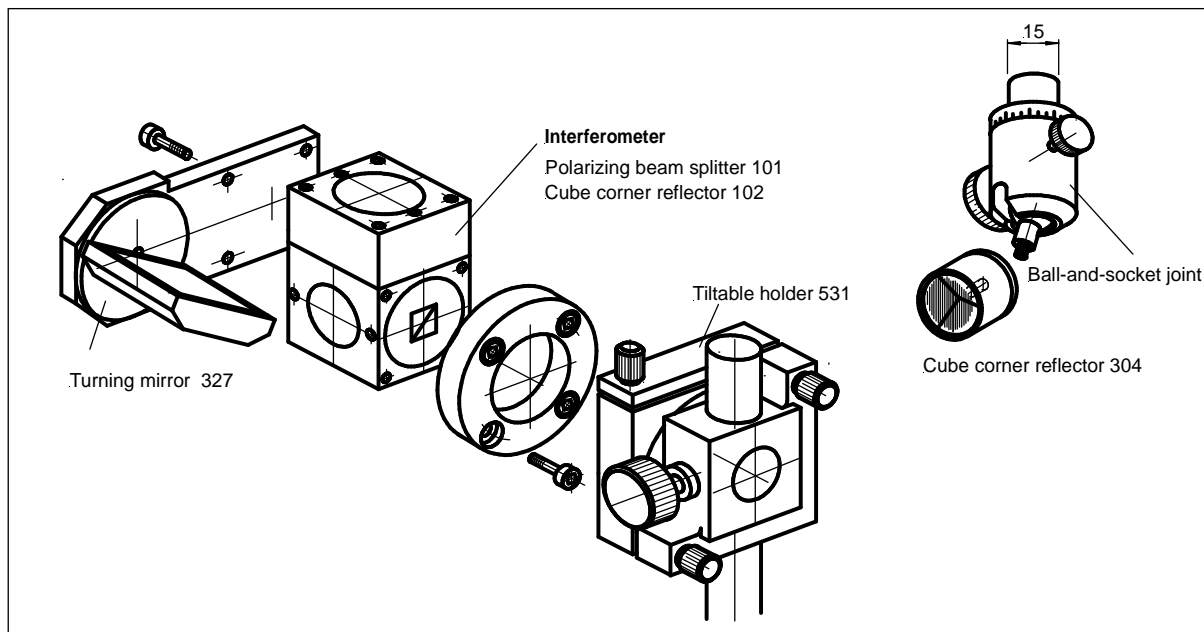
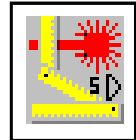


Fig. 12: Setup of the optics for the diagonal measurement



## Adjustment

The justification of the Michelson interferometer was already described in detail in the previous chapter. At the diagonal measuring is in addition between interferometer and laser measuring head a turning mirror.

The right adjustment of the turning mirror 327 is shown in the Fig. 13.

The turning mirror 327 is always adjust around half the amount of the angle between the horizontal beam direction (of the laser measuring head) to the diagonal measuring direction

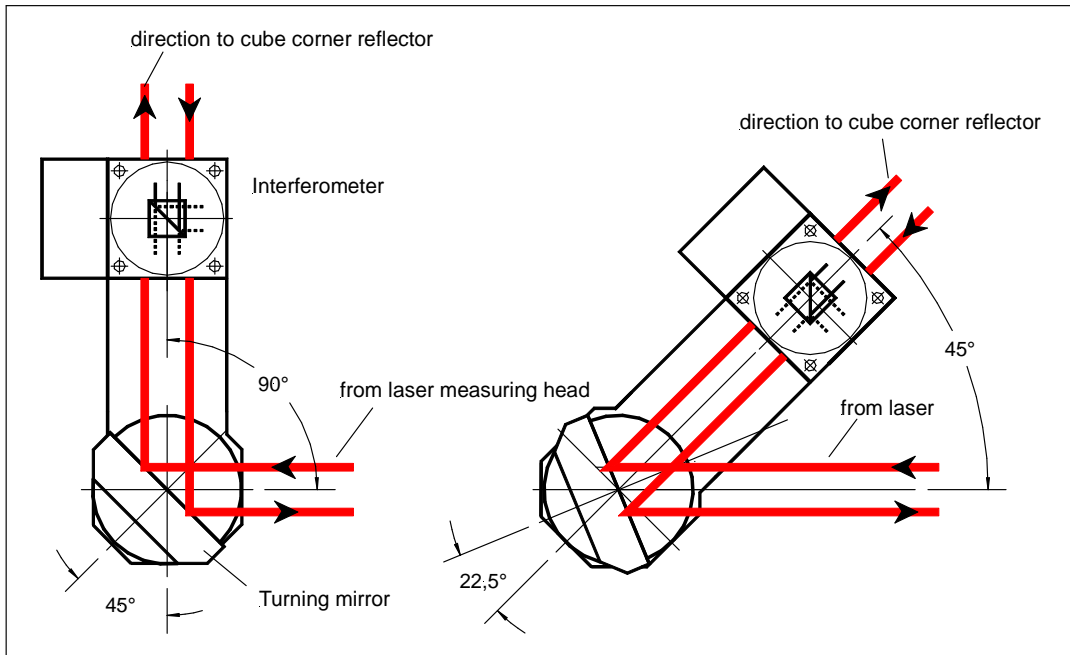


Fig. 13: Adjustment of the turning mirror 327  
(example 1: 90° angle between measuring direction and incident laser beam  
example 2: 45° angle between measuring direction and incident laser beam)

Diagonal measurements in an angular range between 22,5° and 135° can be realized by the extension kit "Diagonal measurement" (Fig. 14)

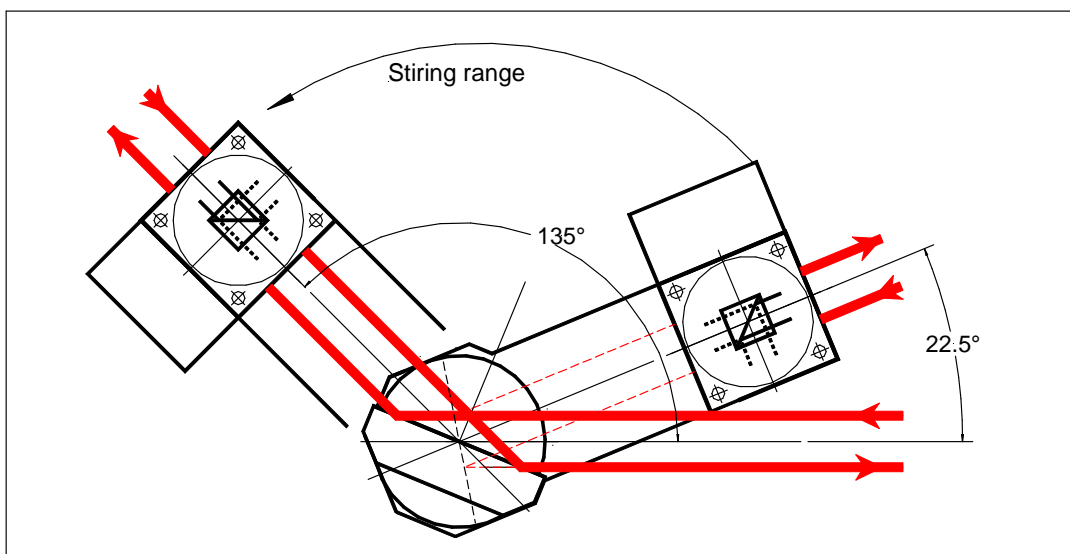


Fig. 14: Tilting range of the turning mirror for the diagonal measurements