

## B Plane Mirror Interferometer Configurations

Plane mirror interferometers are the ideal solution for special duty with a resolution of 1.25nm. Those used for distance, speed and acceleration measurement consist of the following optical components (Fig. 1):

<b>1 Polarizing beam splitter 101</b>	<i>269302-4010.124</i>
<b>1 Corner reflector 102</b>	<i>269302-4010.224</i>
<b>1 Plane mirror 103 (reference)</b>	<i>269302-4010.324</i>
<b>1 Plane mirror 103 (measurement)</b>	<i>269302-4010.324</i>
<b>2 <math>\lambda/4</math>-Plate 104</b>	<i>269302-4010.424</i>

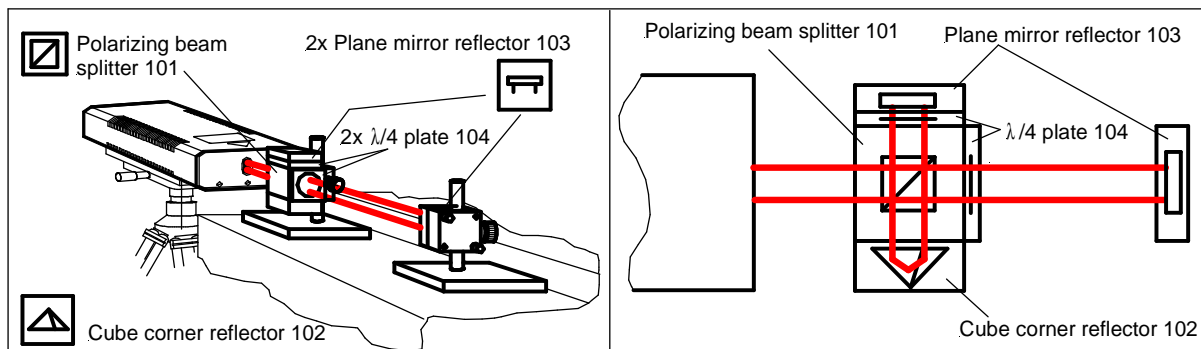


Fig. 1: Plane Mirror Interferometer (optical arrangement)

### Functional description

The light emerging from the laser head serves as the measurement beam, which passes an interferometer arrangement followed by a measuring and a reference reflector, and strikes a detector E1. Because of a polarizing beam splitter in the interferometer, the measuring reflector only receives light of frequency  $f_1$ , while the reference reflector only receives light of frequency  $f_2$ .

Passing the retardation plates ( $\lambda/4$  - plates) the both frequencies are circularly polarized. On return back the measurement beam (reflected by the plane mirror) is reflected by the polarizing beam splitter coating. The reference beam is not reflected by the polarizing beam splitter coating.

The two beams are reflected by the corner reflector and then they travel to their respective plane mirror again. When they pass the retardation plates last time, the both frequencies are linearly polarized. The total of turns of polarization direction is an angle of  $180^\circ$  (same as to begin). The reference beam is reflected back into the laser head by the polarizing beam splitter coating. The measurement beam passes the coating and enters the laser head.

With the measuring reflector at rest, E1 detects the laser's differential frequency ( $f_1 - f_2 = 640$  MHz), which is equal to the electronic reference signal (E2) detected in the laser head. As the measuring reflector is displaced, the beam portion of frequency  $f_1$ , reflected by this reflector, is Doppler-shifted by  $\pm 2df_1$ . Accordingly, detector E1 registers a measuring frequency of  $\Delta f + 2df_1$  or  $\Delta f - 2df_1$ , depending on which way the measuring reflector is moved. The two signals detected (E1 and E2) are compared with each other in the high-frequency section of the laser interferometer system. The result obtained is the frequency shift  $\pm 2df_1$  due to the Doppler effect; this shift is a measure of the path of the measuring reflector, from which the displacement of the measuring reflector is counted (Fig. 2).

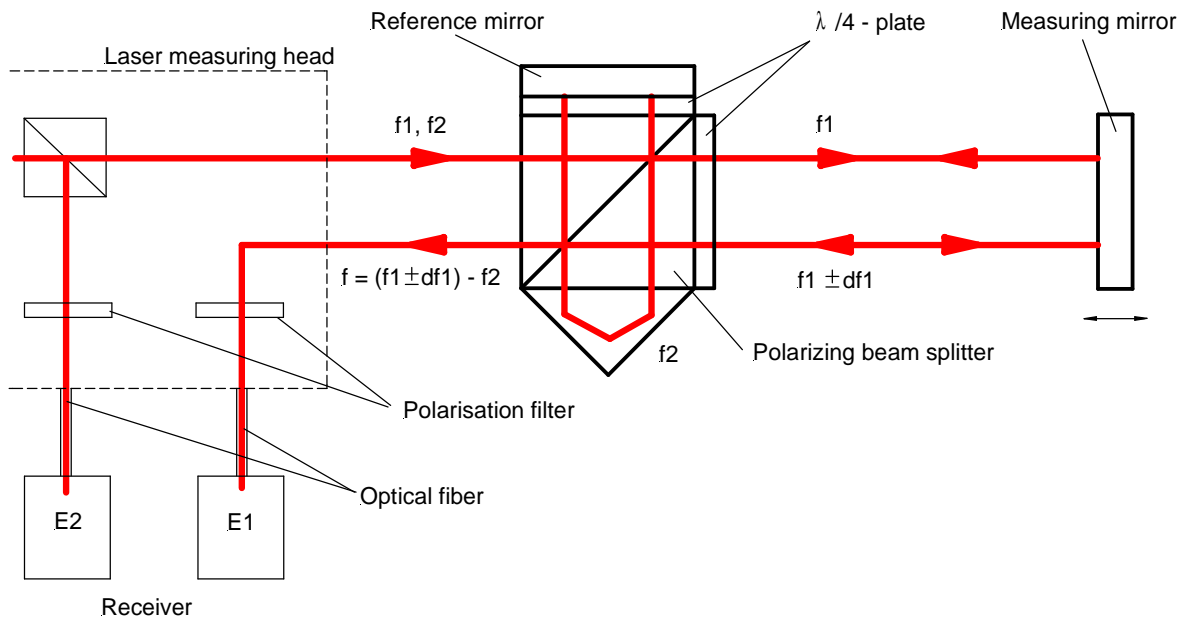
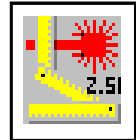
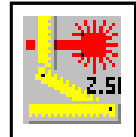


Fig. 2: Plane mirror interferometer (operating principle)

### Assembly

Fig. 3 shows the optical and mechanical modules and components that make up a 1.25nm-resolution plane mirror interferometer. Fig. 1 presents the overall configuration of the functional system (the tripod and the adjustable table are not shown). Fig. 4 depicts the assembly of the modules and components, and Fig. 5 illustrates a practical application at a machine tool. Thanks to the system's modular design, other setups are also possible. For the contents of the carrying cases and the placement of the components therein, see Fig. 7 in section "Assembly of Modules and Components".



**Plane Mirror Interferometer  
(distance measurement, 1.25nm resolution)**

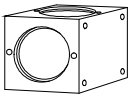
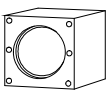


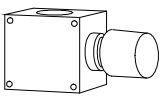
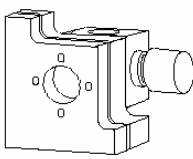

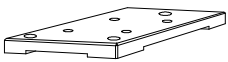
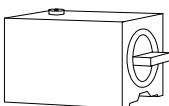


<p><b>Polarizing beam splitter 101</b> 269302-4010.124</p>		<p>Quantity: 1</p>
<p><b>Corner reflector 102</b> 269302-4010.224</p>		<p>Quantity: 1</p>
<p><b>Plane mirror 103</b> 269302-4010.324</p>		<p>Quantity: 2</p>
<p><b><math>\lambda/4</math>-Plate 104</b> 269302-4010.424</p>		<p>Quantity: 2</p>
<p><b>Clamping fixture 507</b> 269302-4010.325</p>		<p>Quantity: 1</p>
<p><b>Clamping fixture 532</b> 269302-4040.625</p>		<p>Quantity: 1</p>
<p><b>Beam stop plate 516</b> 269302-4014.210</p>		<p>Quantity: 2</p>
<p><b>Mounting plate 504</b> 269302-4014.410</p>		<p>Quantity: 2</p>
<p><b>Magnetic chuck 506</b> 260298-3000.128</p>		<p>Quantity: 2</p>
<p><b>Column pin 140</b> 260297-9900.128</p>		<p>Quantity: 2</p>
<p><b>Set of screws</b> 269302-4005.624</p>		<p>Quantity: 1</p>

Fig. 3: Optical and mechanical components of the Plane Mirror Interferometer

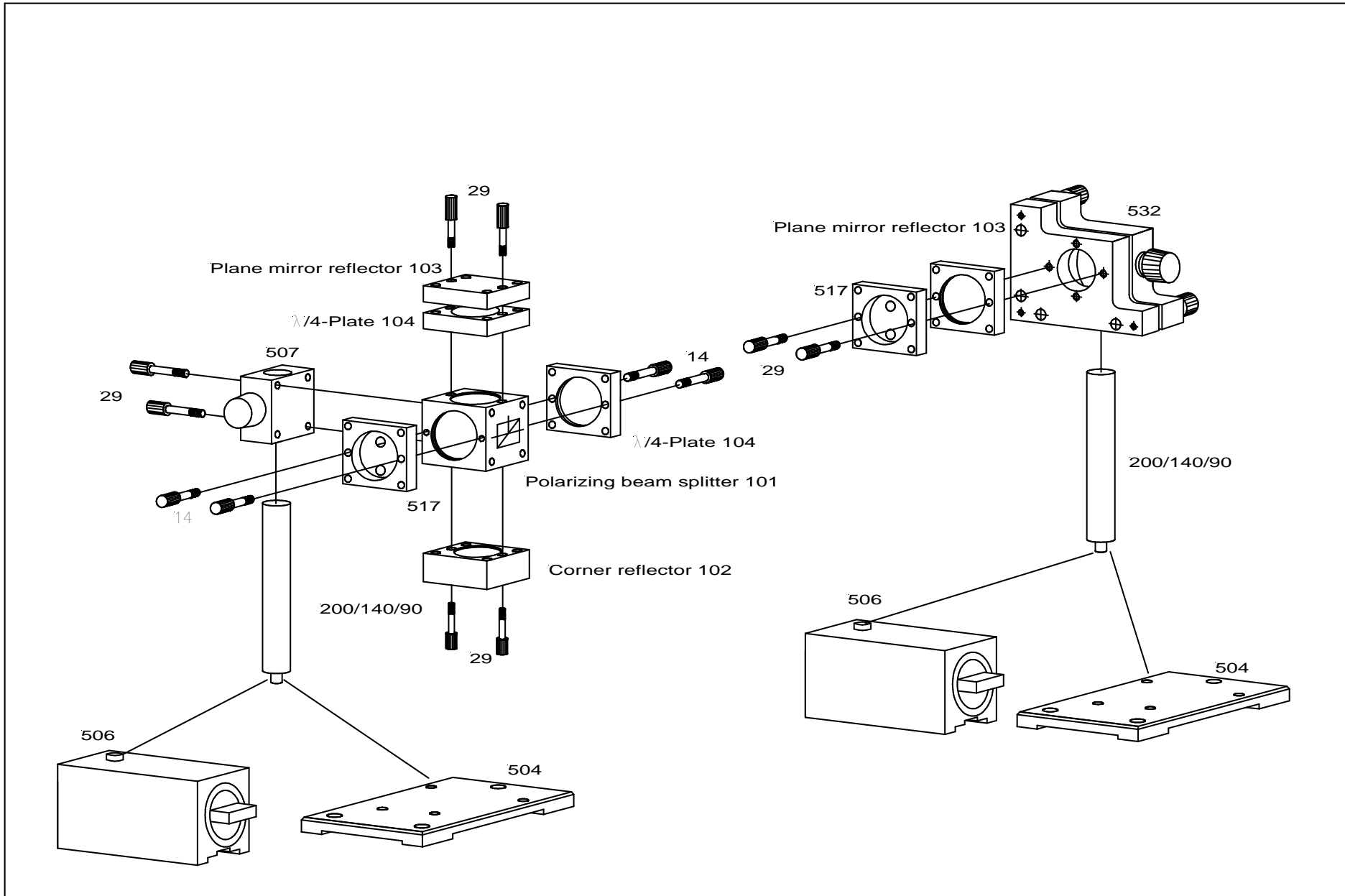


Fig. 4: Optical assembly

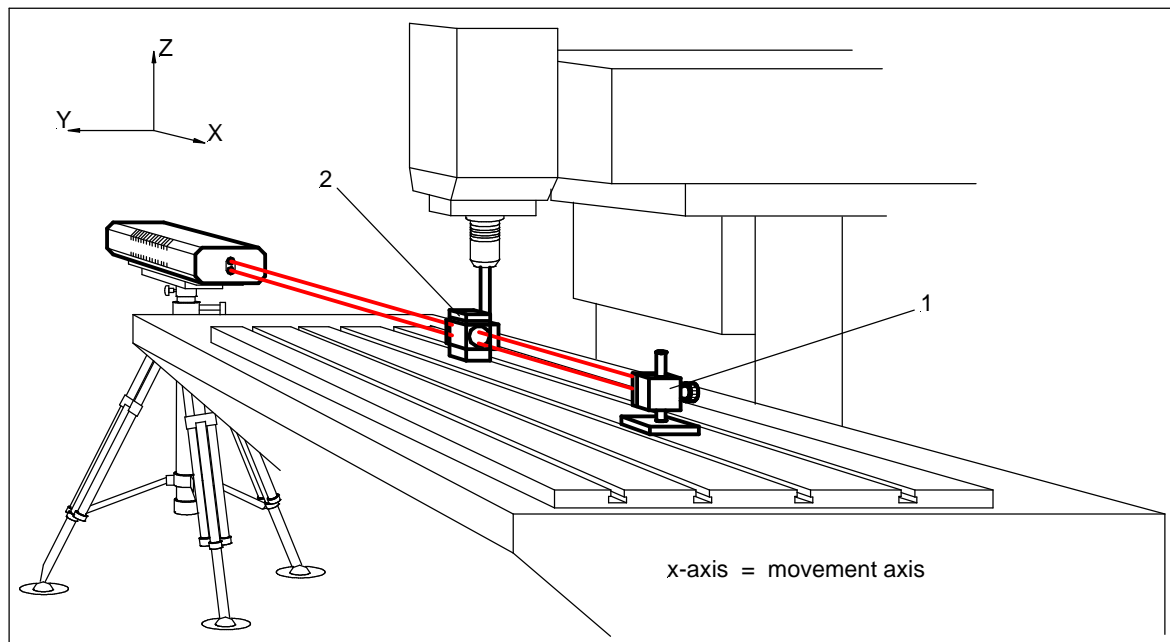
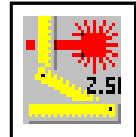


Fig. 5: Measurement setup at a machine tool

### Measurement assembly

With all modules and components assembled, the configuration consisting of **laser head, interferometer and plane mirror** can be set up on the object to be measured. The setting-up procedure should follow the sequence of steps described below:

1. Identify the axis of motion to be measured and find a location on the moving part of the object where the optical system can be fixed (1).
2. Find a stationary datum point in line with the axis of movement (2).



#### IMPORTANT:

The optical modules must be so located that the point of location on the motion axis, the stationary datum point of fixing the interferometer and the beam exit port of the laser head can be aligned on a line in parallel with the motion axis (Fig. 6).

3. Fix the optical modules at the locating points found, wherever possible, in order to reduce measurement errors:

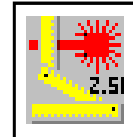
Interferometer  
Plane (measuring) reflector

stationary reference point (2)  
movable reference point (1)



#### IMPORTANT:

Interferometer and plane mirror must have equal distances to the measuring line ( $h_1 = h_2$ , Fig. 6) in order to avoid angular errors.



## Interferometeranordnung – Plane Mirror Interferometer

4. Roughly align the laser beam with the optical axis of the installed optical modules.



### Tips:

- (1) Position the laser head as closely as possible to the interferometer.
- (2) Position the plane mirror at the most distant point possible from the interferometer.
- (3) Check whether the adjustable table is at the centre of its parallel displacement and tilting ranges. This is important to ensure sufficient freedom of adjustment both ways during fine alignment of the beam path.

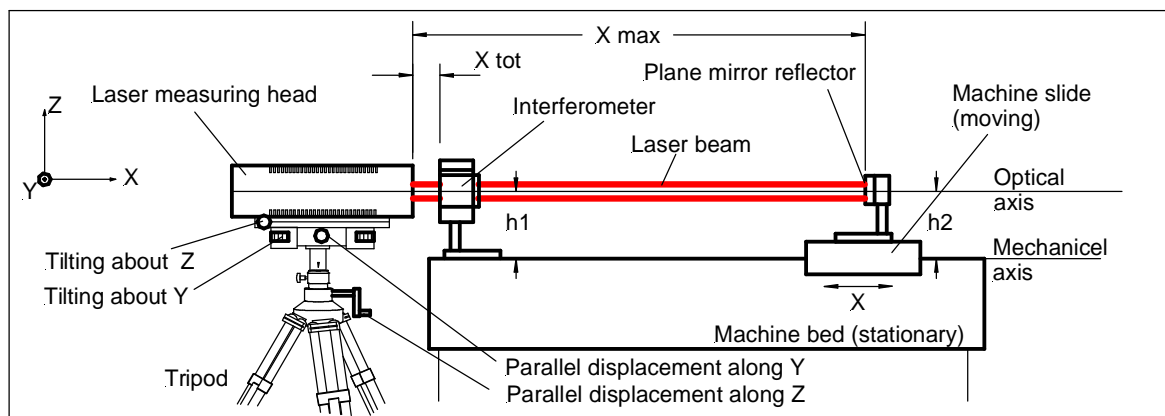


Fig. 6: Measuring setup, optical path

5. Fine alignment of the beam path



### Tip:

To facilitate the alignment of the optical path in parallel with the measuring axis, remove the interferometer from the beam path, leaving only the plane mirror. That way, only one beam returns to the laser head, which makes it easier to assess the state of alignment.

A fundamental distinction is made (Fig. 7) between

positional alignment	(parallel displacement along x and y) ( $\delta x$ , $\delta y$ )
and	
directional alignment	(tilting about x and y) ( $\delta\phi_x$ , $\delta\phi_y$ )

The ZLM 700 is designed so that both adjustment facilities are provided on the adjustable table / tripod assembly. The merit of this arrangement is that you do not have to constantly alternate between two adjusting locations (laser head - measuring reflector).

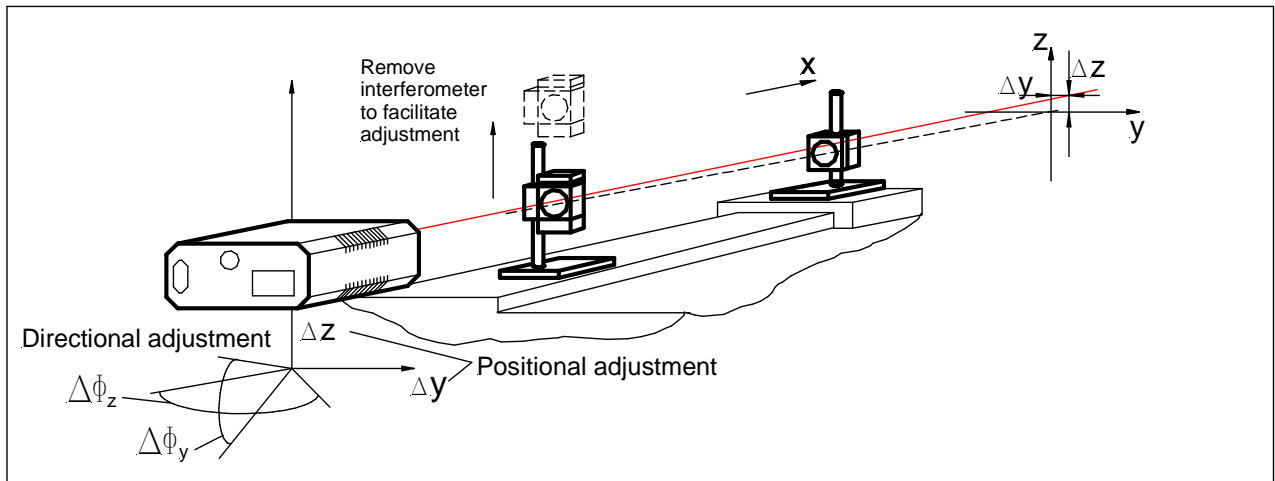
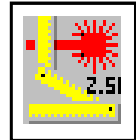


Fig. 7: Alignment of the beam path

The location of the plane mirror relative to the interferometer is important for both positional and directional alignment (Fig. 8):

Positional alignment, parallel displacement ⇒ at the plane mirror position nearest to the laser

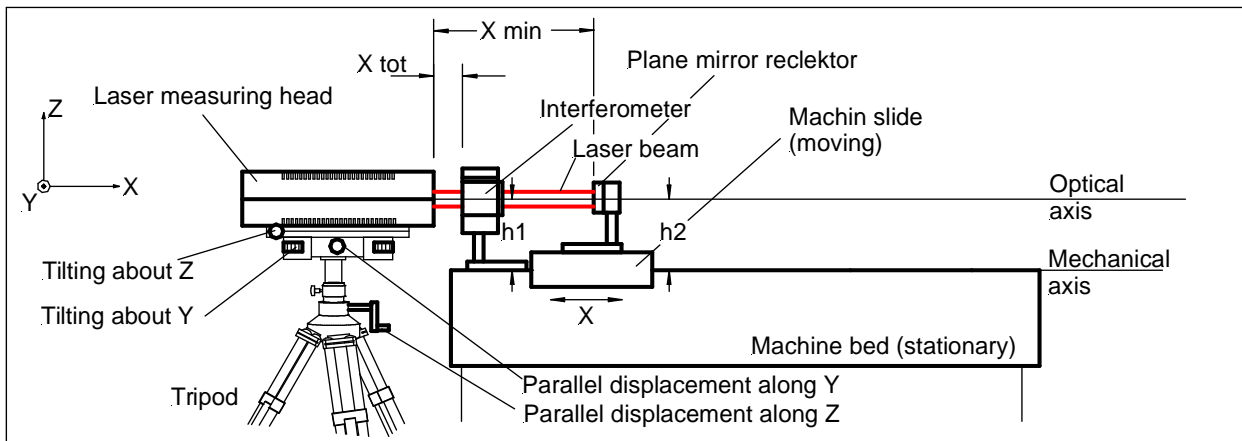
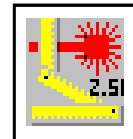


Fig. 8: Positional alignment of the beam path



Directional alignment, tilting  $\Rightarrow$  at the plane mirror position most distant from the laser head

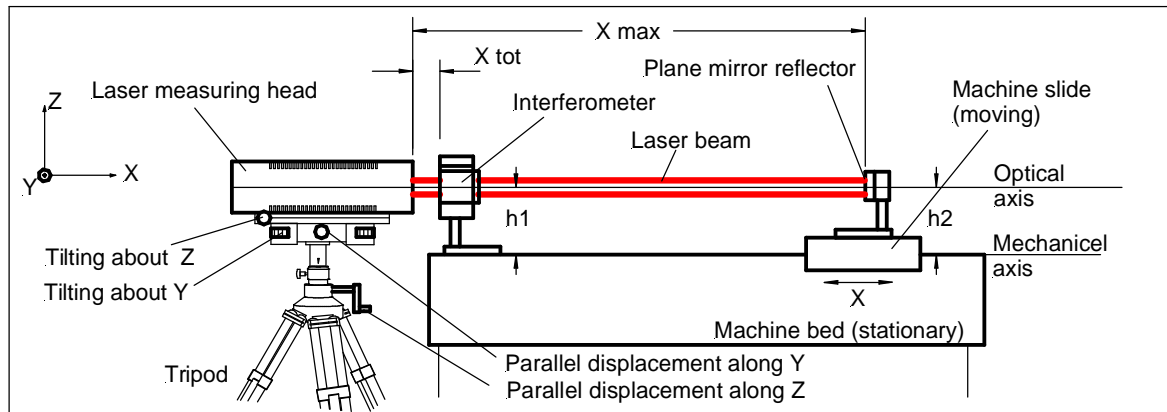



Fig. 9: Directional alignment of the beam path

## Adjustment

From these basic principles, the following procedure of aligning the beam path results:



1. Select menu item  in the "Measurement" program routine.  
In this menu item, the powers of the two beams reflected back into the laser head (reference and measuring beams) are represented by two spots on the monitor screen. (prerequisite: alignment the interferometer in the beam path) The screen graph immediately shows the effect of alignment manipulations and thus allows the quality of alignment of the two beams to be checked and optimized.
2. Move plane mirror to the point most distant from the laser head and fix it there (Fig. 9).  
Adjust the laser beam direction in y and z:

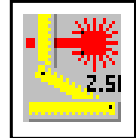
$\Delta\Phi_y$  - Turn the two lateral knurled screws of the adjustable table,  
 $\Delta\Phi_z$  - Turn the two knurled height adjustment screws of the adjustable table.

Align until the reflected beam hits the beam entrance port of the laser head.  
 For fine alignment, use the cross-lines shown on the screen.

3. Move the plane mirror to the point closest to the laser and fix it there (Fig. 8). Adjust the laser position in y and z:

$\Delta y$  - Turn the micrometer screw of the adjustable table to displace the laser in parallel.  
 $\Delta z$  - Turn the height adjustment handwheel of the tripod.

Align until the reflected beam hits the beam entrance port of the laser head.  
 For fine alignment, use the cross-lines shown on the screen.



Repeat steps 2 and 3 alternately until no significant change in beam position (relative to the screen cross-lines) can be noticed.  
The permanent angular error between the optical and mechanical axes can be seen as the blue moving bar below the cross-lines presentation.



### **IMPORTANT:**

Pay attention to the same local situation of the points of measuring and reference beam in the cross-lines.  
(importantly for perfect interferenc signal education)



### **Note:**

The aligning of the interferometer doesn't influence the adjusted beam path of the plane mirror.

Aligning the interferometer completes the alignment of the setup, which is now ready for measurement (see the Software Manual).