

Straightness Interferometer

E Interferometer for Straightness Measurement

At the flatness measuring the deviations of straightness are measured indirectly by the progressive angle measuring. Unlike this deviations of straightness can be measured also directly by interferometer. Mirror areas which are worked very exactly in their planeness serve as straightness normal. Every unevenness of the mirror causes a systematic fault. The straightness deviations of guide ways at machine tools, coordinate measuring engines or other engines and devices particularly simply can be measured with the laser interferometer system.

The straightness interferometer serves the beam splitting. Double wedge and corner reflector constitute this straightness normal (Fig. 2).

Functional description

The light emerging from the laser unit enters a differential interferometer as the measuring beam. The vibration planes of the two frequencies emitted, f1 and f2, are perpendicular to each other (Fig. 3).

Fig. 1:
In the laser beam, the vibration plane of f1 is vertical, and that of f2 is horizontal.

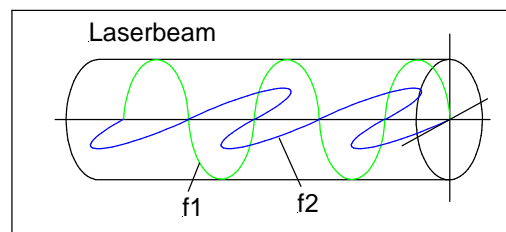

Because of their different vibration planes (Fig. 1), the two frequencies are separated by a beam-splitting polarization coating in the differential interferometer.

Frequency f1 is deflected by 90°, as its vibration plane is parallel to the position and direction of the beam-splitting polarizer coat. It then passes the interferometer's half-wave plate, gets its vibration plane rotated by 90° and is deflected again by 90° by the interferometer.

Frequency f1 then passes a quarter-wave plate, after which it is again parallel to f2, which has passed the interferometer unaffected, thanks to its different direction of polarization. Passing the respective retardation plates (f1: $\lambda/2$ and $\lambda/4$ plates, f2: $0 \lambda/2$ plate) subjects both frequencies to circular polarization.

On striking the double wedge, both frequencies are refracted at a defined angle and then fall perpendicularly on the surfaces of the angular reflector, which reflects them back on themselves through the double wedge and to the interferometer. When they pass the retardation plates, both frequencies regain plane polarization, are reflected by the optical layers depending on their polarization direction and strike the respective corner reflector in the lower tier of the optical arrangement (tier II). Analogously to tier I (Fig. 4), both frequencies again travel along the optical path formed by interferometer, double wedge, angular reflector and back; when they pass the retardation plates again, their vibration planes are rotated. Now, frequency f1 vibrates horizontally and frequency f2 vertically, relative to the direction of beam incidence. Therefore, f1 is reflected by the polarizing beam-splitter coating at an angle of 90° relative to the laser head, whereas f2 passes the coating and enters the laser head.

With the double wedge being stationary, detector E1 registers the differential frequency of the laser ($f1 - f2 = 640 \text{ MHz}$), which is equal to the electronic reference signal E2 detected in the laser head. If the double wedge is moved, the optical path lengths of the two frequencies passing it are changed, so that the respective measuring distance δz becomes either shorter or longer. The frequency changes ($df1, df2$) are proportional to the transverse displacement of the double wedge. They are detected by detector E1, since the beam has travelled the optical path twice.

$$\Delta f = (f1 + 4df1) - (f2 - 4df2) \quad \text{oder} \quad \Delta f = (f1 - 4df1) - (f2 + 4df2)$$

depending on the direction of mirror displacement.

In the high-frequency section of the laser interferometer system, the two detected signals (E1 and E2) are compared with each other. The result obtained is the frequency shift produced by the Doppler effect; this shift is a measure of the wanted transverse displacement of the double wedge.

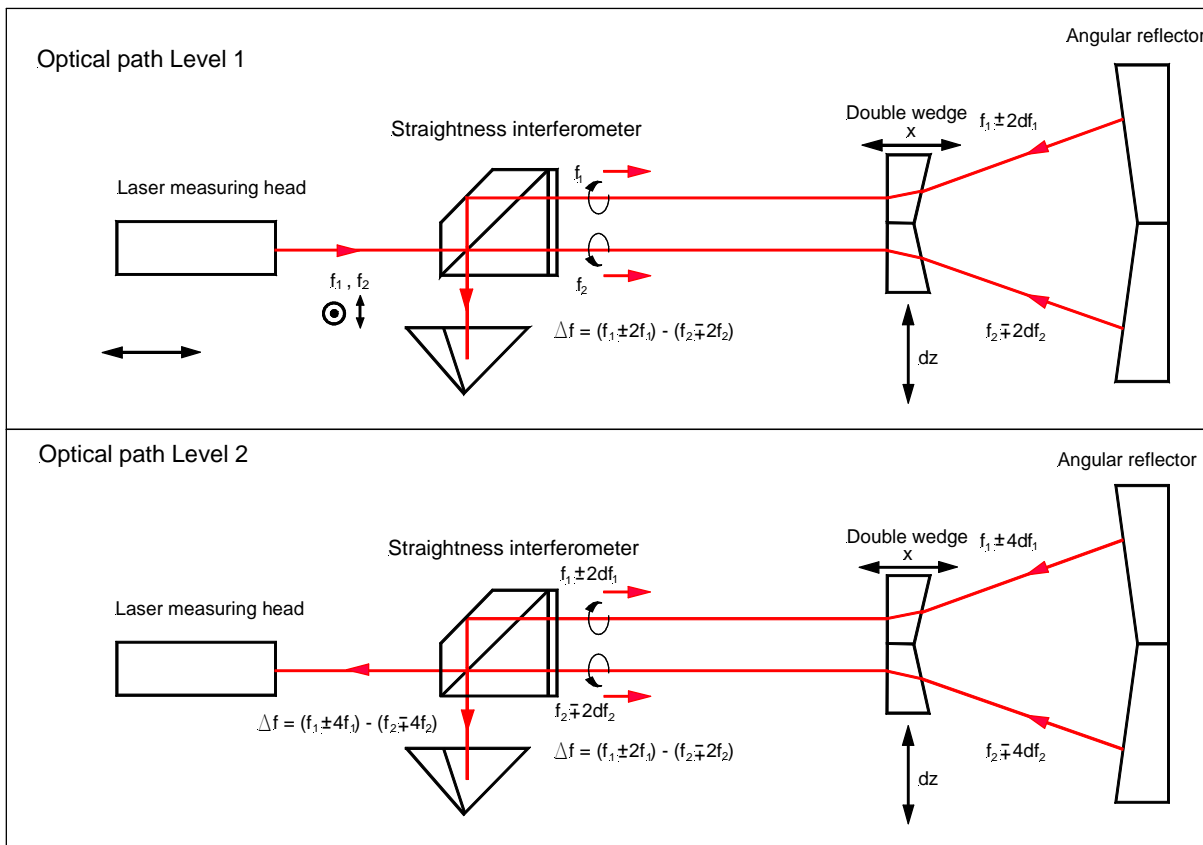
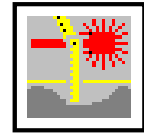

Fig. 2: Optical path in the different levels of the straightness interferometer

It must be distinguished

1. the detection of horizontal straightness errors
2. the detection of vertical straightness errors

At a vertical straightness measuring the Beam offset prism 120 must in addition be used so that the beam coming back from the interferometer can enter the laser measuring head (Fig. 4b). In the Beam offset prism 120 taking place one beam redirection about diagonal and therewith one shifting to 90°.

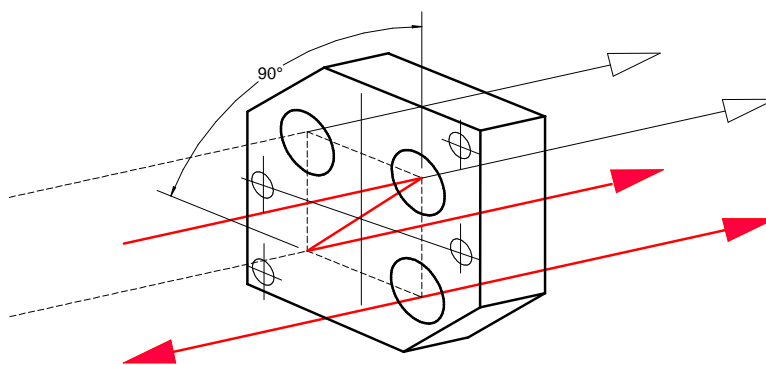
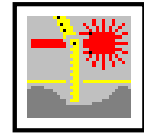

Fig. 3: Function of the Beam offset prism 120



Straightness Interferometer

There are 2 options for the straightness measuring at the ZLM 700:

1. straightness measurement up to **2m length of axis** with a resolution of 29 nm
2. straightness measurement up to **10m length of axis** with a resolution of 145 nm

The optical moduls of the straightness measurement are:

1 Straightness interferometer 128	269302-4012.824
1 Beam offset prism 120	269302-4008.424
1 Double wedge 108 (2m)	269302-4010.824
or 112 (10m)	269302-4011.224
1 Angular reflector 109 (2m)	269302-4010.924
or 113 (10m)	269302-4011.324

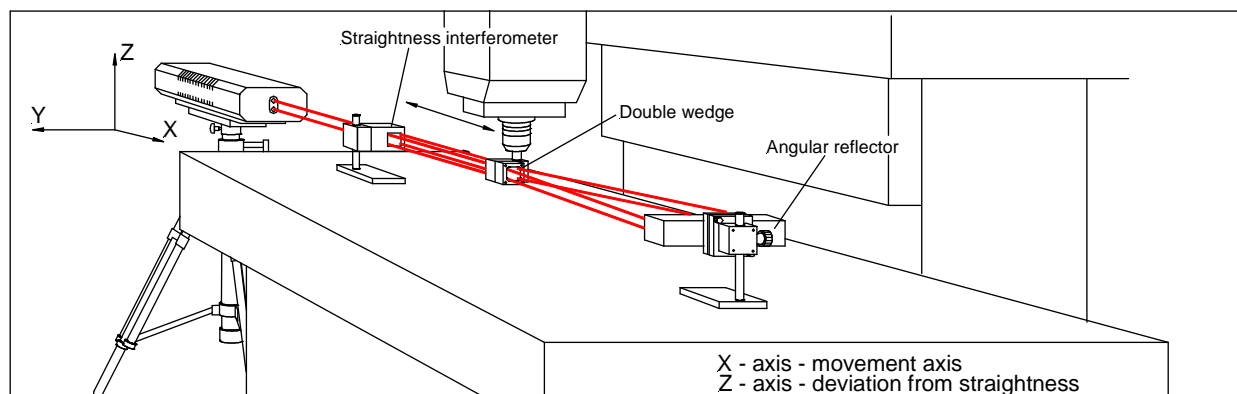

Fig. 4a: Measurement of straightness errors, horizontal configuration

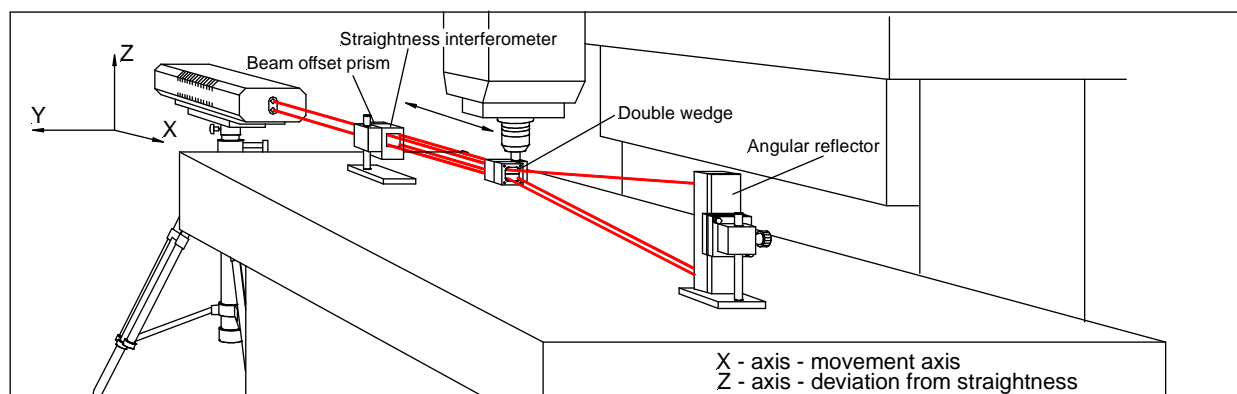
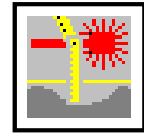

Fig. 4b: Measurement of straightness errors, vertical configuration



Straightness Interferometer

Assembly

The optical and mechanical modules and components of the equipment are shown by Fig. 5. Figs. 6 and 7 illustrate their assembly.

Straightness interferometer (*horizontal / vertical setup*)

Differential interferometer 128 2693 02- 4012.824		Quantity: 1
Double wedge 2m / 10m 269302- 4010.824 2m 269302- 4011.224 10m		Quantity: 1
Angular reflector 2m / 10m 269302-4010.924 2m 269302-4011.324 10m		Quantity: 1
Beam offset prism 269302-4008.424		Quantity: 1
Tiltable fixture 524 269302-4010.925		Quantity: 1
Clamping fixture 508 269302-4010.125		Quantity: 2
Clamping fixture 507 269302-4010.325		Quantity: 1
Mounting plate 504 269302-4014.410		Quantity: 2
Magnetic base 506 260298-3000.128		Quantity: 2
Column pin 90 140 or 200 260297-9900.128		Quantity: 2
Set of screws 269302-4005.624		Quantity: 1

Fig. 5: Optical and mechanical modules and components of the Straightness Interferometer

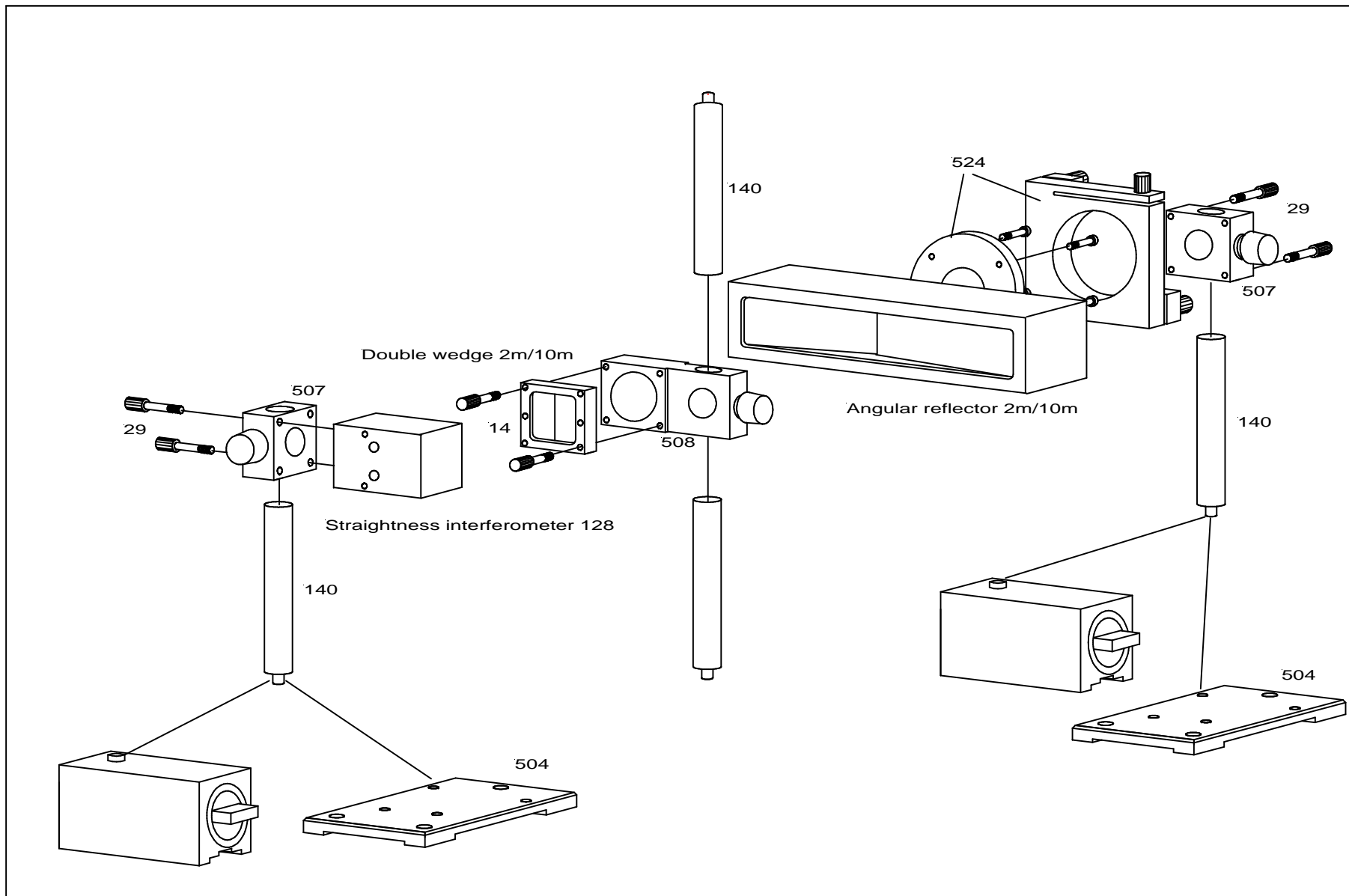

Fig. 6: Straightness interferometer, horizontal configuration (assembly drawing)

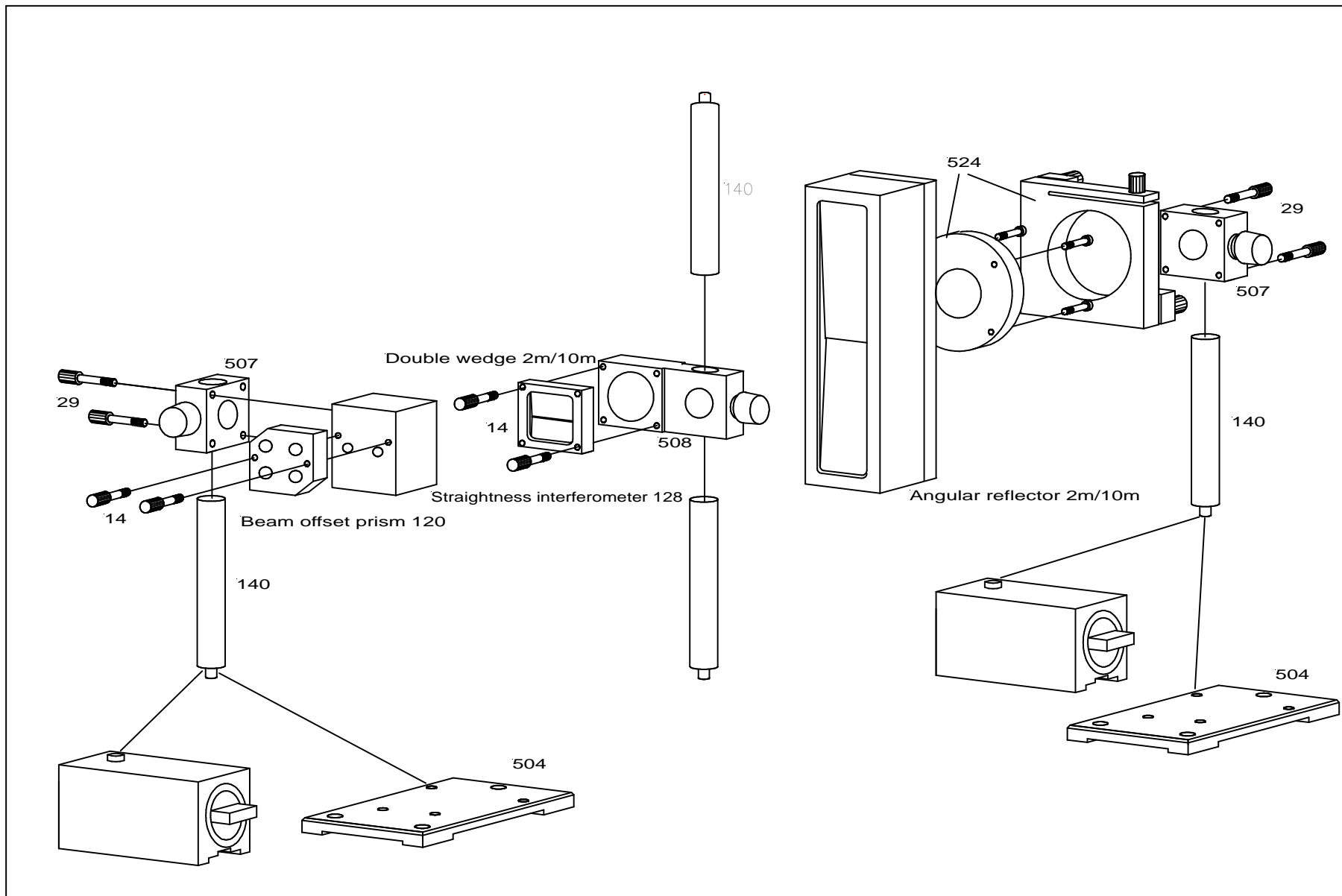
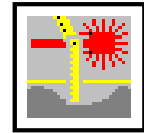

Fig. 7: Straightness Interferometer, vertical configuration (assembly drawing)



Measurement assembly

If all components (**laser head - straightness interferometer 128 - double wedge - angular reflector**) are assembled, the adjustment can start at the measurement object.

The set-up should be carried out for the two configurations (horizontal, vertical set-up) in the following steps:

1. Identify the axis of motion to be measured and find a location on the moving part of the object where the Double wedge can be fixed (1).
example: fig. 8 Spindle chuck (pinole) - Double wedge
2. Find two stationary reference points in line with the axis of motion, at which the interferometer and the angular reflector can be rigidly fixed.
*example: fig. 8 Machine bed - Angular reflector
Machine bed - Interferometer*



IMPORTANT:

The optical modules must be so located that the point of location on the motion axis, the stationary reference point of fixing the interferometer and the beam exit port of the laser head can be aligned on a line in parallel with the motion axis.

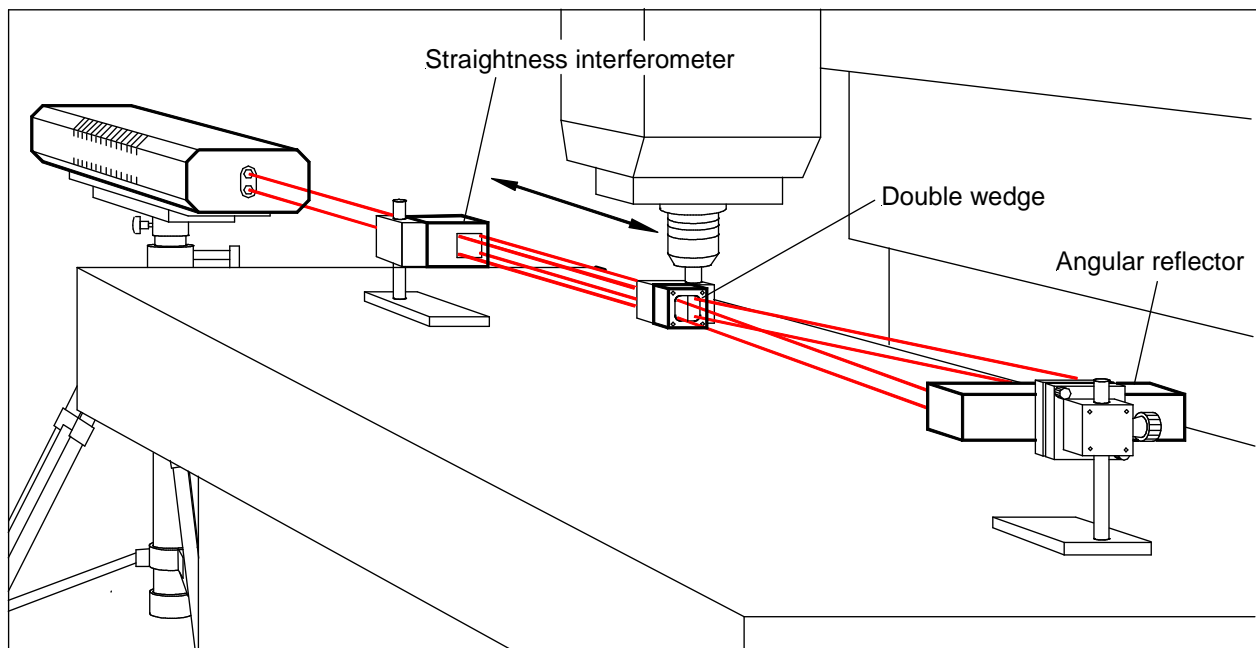

Fig. 8: Measurement setup at a machine tool

3. Fix the optical modules at the locating points found, wherever possible, in order to reduce measurement errors.



IMPORTANT:

Interferometer and corner reflector must have equal distances to the measuring line ($h_1 = h_2$) in order to avoid angular errors. fig. 9

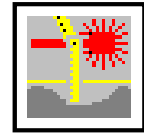

4. Roughly align the laser beam with the optical axis of the installed optical modules.



Tips:

- (1) Position the laser head as closely as possible to the interferometer (X_{tot}).
- (2) Position the angular reflector at the most distant point possible from the interferometer (X_{max}) (Fig.9).
- (3) Check whether the adjustable table is at the centre of its parallel displacement and tilting ranges. \Rightarrow This is important to ensure sufficient freedom of adjustment both ways during fine alignment of the beam path.

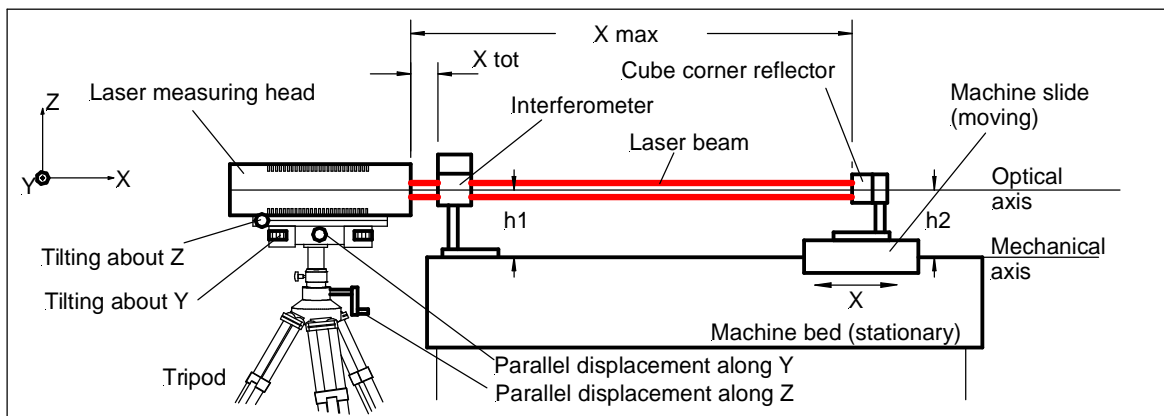

Fig. 9: Measuring setup, optical path

5. Fine alignment of the beam path



Tips:

To facilitate the alignment of the optical path in parallel with the measuring axis, remove the Double wedge from the beam path and fix a corner reflector in the beam path \Rightarrow That way, only one beam returns to the Straightness interferometer 128, which makes it easier to assess the state of alignment. \Rightarrow using the direct beam (see fig. 10), (covering the other beam)

Advice: As Cube corner reflector the Double corner reflector 160 can be used.

This is exchanged directly with the double wedge. At use of the Cube corner reflector 102 has to make sure, that the center by 7.5 mm is transposed. The Adapter plate 542 serves as a compensation.

A fundamental distinction is made (Fig. 10) between

- positional alignment (parallel displacement along y and z) ($\Delta y, \Delta z$)
- directional alignment (tilting about y and z) ($\Delta\phi_y, \Delta\phi_z$)

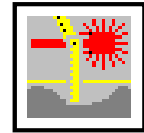

Straightness Interferometer

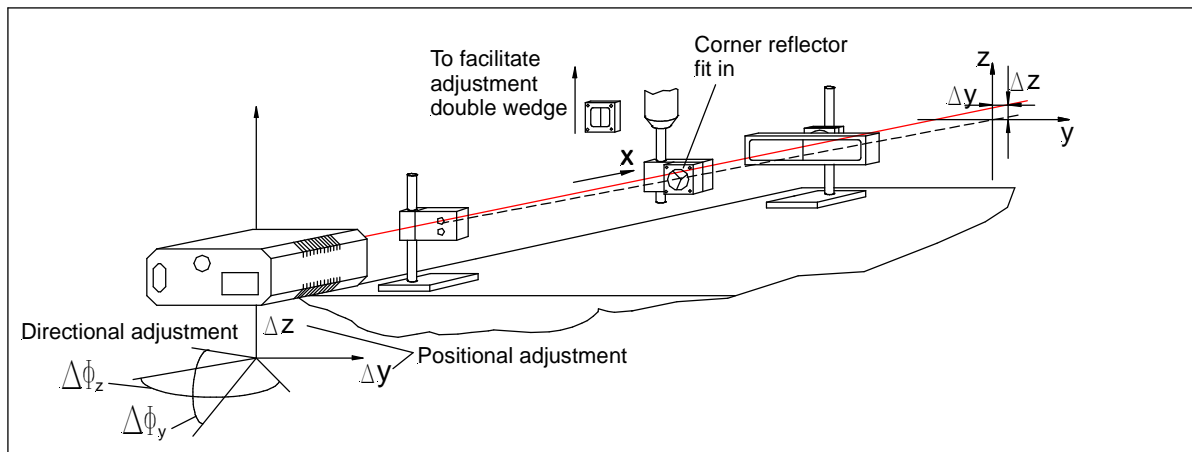

FFig. 10: Beam alignment with cube corner reflector

The ZLM 700 is designed so that both adjustment facilities are provided on the adjustable table / tripod assembly. The merit of this arrangement is that you do not have to constantly alternate between two adjusting locations (laser head - measuring reflector).

For place and direction justification it is very important the position (place) of the Cube corner reflector to the Straightness interferometer (see fig.s 11, 12).

Positional alignment, ⇔ at the Cube corner reflector position nearest to the laser
 Parallel displacement

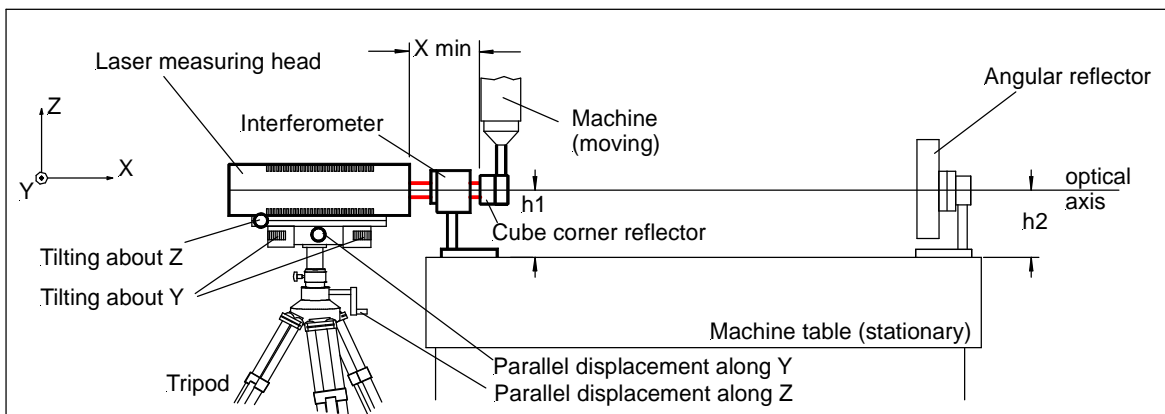

Fig. 11: Positional alignment of the beam path

Directional alignment, tilting ⇔ at the corner reflector position most distant from the laser head

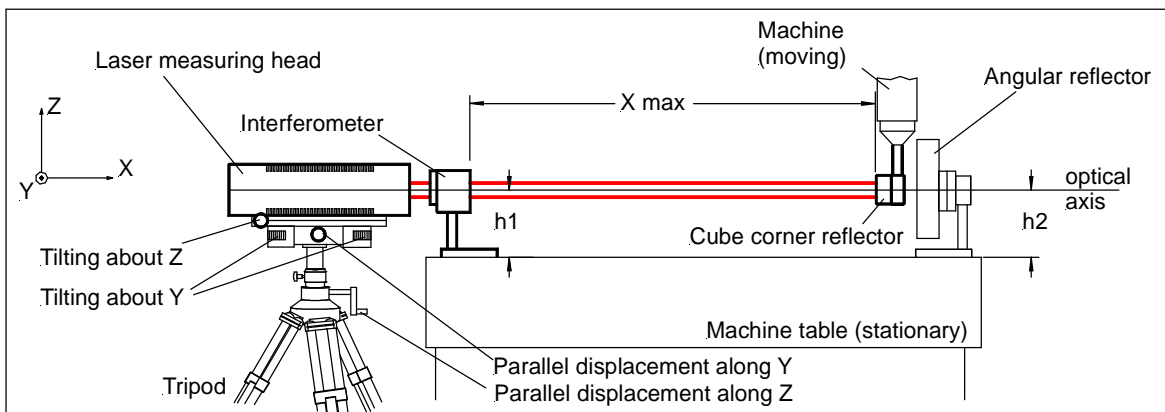
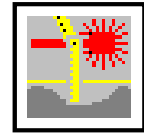



Fig. 12: Directional alignment of the beam path



Adjustment

From these basic principles, the following procedure of aligning the beam path results:



- 1) Select menu item  in the "Measurement" program routine.
In this menu item, the powers of the two beams reflected back into the laser head (reference and measuring beams) are represented by two spots on the monitor screen. The screen graph immediately shows the effect of alignment manipulations and thus allows the quality of alignment of the two beams to be checked and optimized.

- 2) Move cube corner reflector to the point most distant from the laser head and fix it there (Fig. 12).
Adjust the laser beam direction in y and z:
 $\Delta\Phi_y$ - Turn the two lateral knurled screws of the adjustable table;
 $\Delta\Phi_z$ - Turn the two knurled height adjustment screws of the adjustable table.

Align until the reflected beam hits the beam entrance port of the laser head.
For fine alignment, use the cross-lines shown on the screen.

- 3) Move cube corner reflector to the point closest to the laser and fix it there (Fig. 13).
Adjust the laser position in y and z:

Δy - Turn the micrometer screw of the adjustable table to displace the laser in parallel.
 Δz - Turn the height adjustment handwheel of the tripod.

Align until the reflected beam hits the beam entrance port of the laser head.
For fine alignment, use the cross-lines shown on the screen.

Repeat steps 2 and 3 alternately until no significant change in beam position (relative to the screen cross-lines) can be noticed.
The permanent angular error between the optical and mechanical axes can be seen as the blue moving bar below the cross-lines presentation.

- 4) align the angular reflector by the following steps, Fig. 13
 - Exchange Cube corner reflector – Double wedge
 - horizontal and vertical justification of the Angular reflector on the two beams of the upper level



IMPORTANT:

Beams must hit the upper mirror face (upper tier) symmetrically to the centre line (roof edge) of the angular reflector.

- Align the Angular reflector by turning the aligning screws of its mounting fixtures so that the beams are reflected back into the incident direction. Both beams must pass again the Double wedge in the upper tier (observe the beams reflected back on to the Double wedge until they coincide with the beams coming from the interferometer). With correct alignment, both beams in the lower tier (Fig. 13) are reflected back on to the angular reflector.

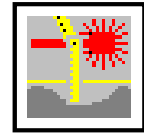

- Both beams are in the lower level (with some lateral offset) of the Angular reflector. Through slightly turning the Angular mirror reflector is the beam path of the lower level vertically adjusted under the beam path of the upper level (Fig. 13).

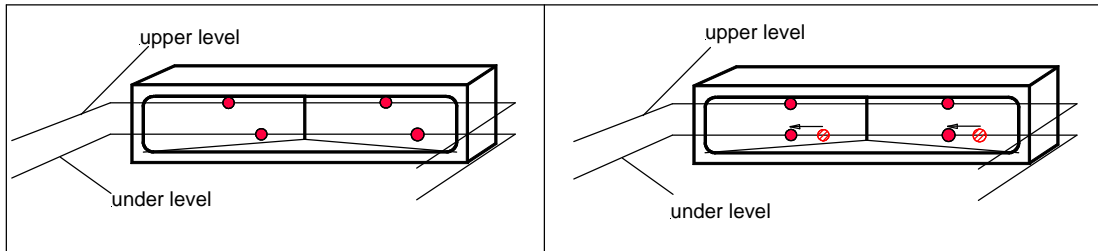

Fig. 13:

By correctly adjustment the laser beam is reflected into the under beam entry of the laser.



Finally, optimize the beam path by means of the screen graph

IMPORTANT

Pay attention to the same local situation of the points of measuring and reference beam in the cross-lines.
(importantly for perfect interferenc signal)

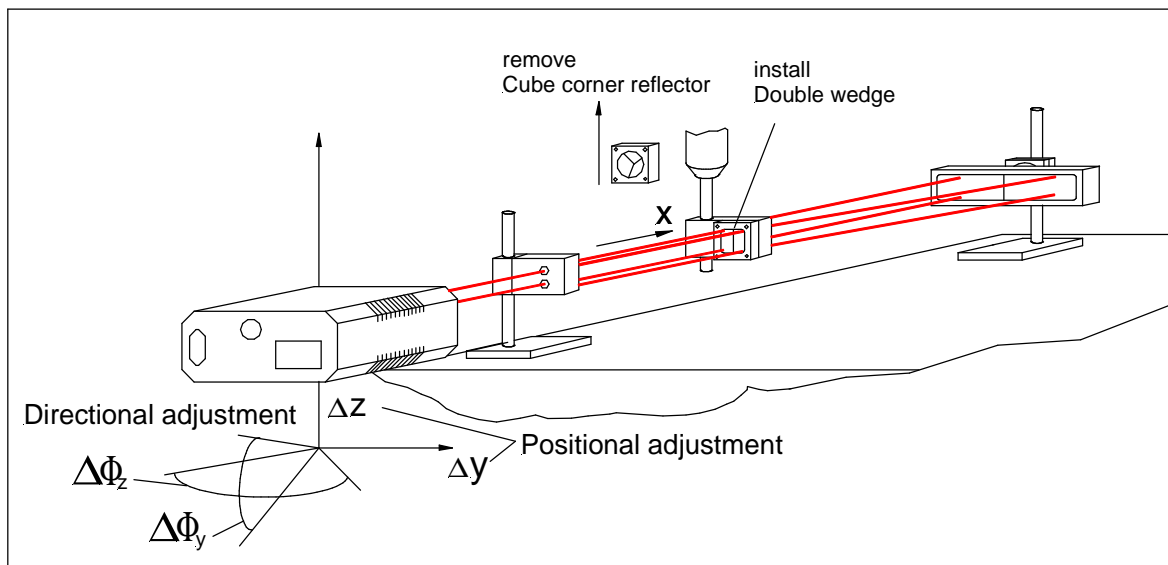

Fig. 14: Adjustment of the interferometer with the Double wedge

With the adjustment of Double wedge and Angular mirror reflector complete the alignment of the setup, which is now ready for measurement (see the Software Manual).