

## Interferometer for vibration measurement

### H Focus - Touching

At this kind of interferometer the light of the measuring arm of the interferometer can be focalized by means of a converging lens directly on a measuring object.

This makes it possible to use very small mirrors or reflective surfaces. Though so can be measured only in a movement area of approximately  $\pm 0.2$  mm. Therefore the focus-touching is particularly suitable for measuring small movement sequences of operations (e.g. piezo actuators), concentricity measurement at reflective objects and to vibration measurement.

The optics modules required for the focus-touching are:

1 <b>Polarizing beam splitter 101</b>	<b>269302-4010.124</b>
1 <b>Cube corner reflector 102 (as reference reflector)</b>	<b>269302-4010.224</b>
1 <b>Vibrometer ancillary lens 320</b>	<b>269302-4006.424</b>
1 <b>Plane mirror reflector small 317 (as measuring reflector)</b> or a reflecting object surface	<b>269302-4010.324</b>

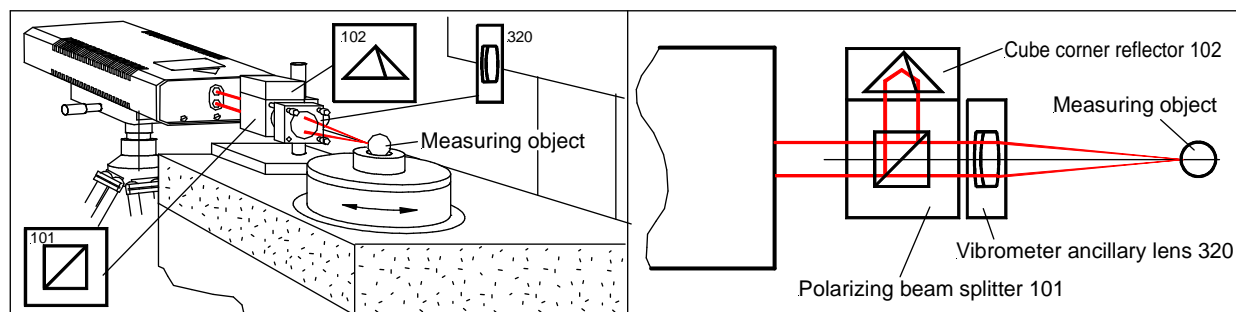


Fig. 1: Optical scheme of focus-touching (concentricity measurement with measuring ball)

### Functional description

The light emerging from the laser head serves as the measurement beam, which passes an interferometer arrangement with lens attachment, followed by a measuring and a reference reflector, and strikes a detector E1.

Because of a polarizing beam splitter in the interferometer, the measuring reflector only receives light of frequency  $f_1$ , while the reference reflector only receives light of frequency  $f_2$ .

With the measuring reflector at rest, E1 detects the laser's differential frequency ( $f_1 - f_2 = 640$  MHz), which is equal to the electronic reference signal (E2) detected in the laser head. As the measuring reflector is displaced, the beam portion of frequency  $f_1$ , reflected by this reflector, is Doppler-Shifted by  $\pm df_1$ . Accordingly, detector E1 registers a measuring frequency of  $\Delta f + df_1$  or  $\Delta f - df_1$ , depending on which way the measuring reflector is moved. The two signals detected (E1 and E2) are compared with each other in the high-frequency section of the laser interferometer system. The result obtained is the frequency shift  $\pm df_1$  due to the Doppler effect; this shift is a measure of the speed of the measuring reflector, from which the displacement of the measuring reflector is computed by integration (Fig. 2).

The **Resolution** of this interferometer with focus-touching is **2,5 nm**.

The **Movement range** is  **$\pm 0,2$ mm**

The **Focal length** of vibrometer ancillary is **200 mm** (distance between lens centre to the focus is **196,12 mm**).

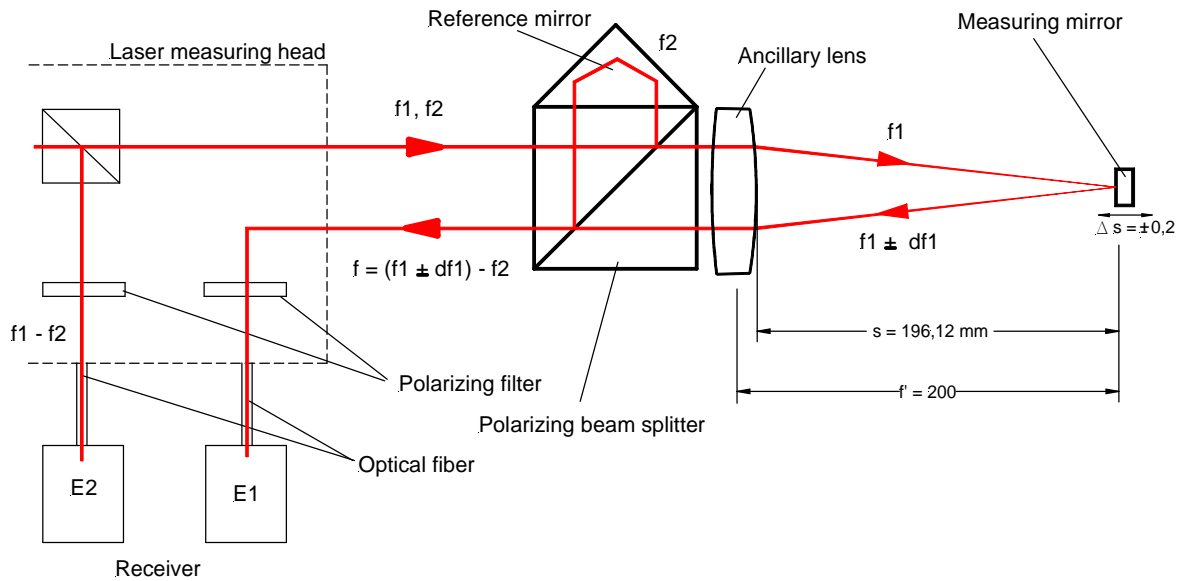
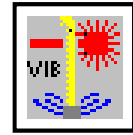
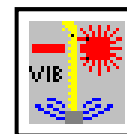


Fig. 2: Operating principle of the focus-touching

### Assembly

Fig. 3 shows the optical and mechanical modules and components that make up a Cube corner reflector interferometer with lens attachment (2.5nm-resolution).

Fig. 1 presents the overall configuration of the functional system (the tripod and the adjustable table are not shown). Fig. 4 depicts the assembly of the modules and components, and Fig. 5 illustrates a practical application. Thanks to the system's modular design, other setups are also possible. For the contents of the transport cases and the placement of the components therein, see Fig. 4 in section "System Description and Operation".



**Cube corner interferometer with lens attachment (2.5 nm resolution)**

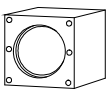
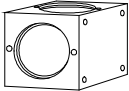



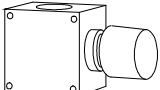

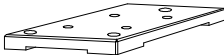
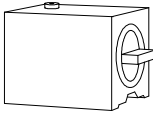



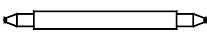
<b>Cube corner reflector 102</b> 269302-4010.224		Quantity: 1
<b>Polarizing beam splitter 101</b> 269302-4010.124		Quantity: 1
<b>Plane mirror reflector small 317</b> 269302-4016.124		Quantity: 1
<b>Vibrometer ancillary lens 320</b> 269302-4006.424		Quantity: 1
<b>Adjusting plate</b> 269302-4006.425		Quantity: 1
<b>Clamping fixture 507</b> 269302-4010.325		Quantity: 1
<b>Beam stop plate 516</b> 269302-4014.210		Quantity: 1
<b>Mounting plate 504</b> 269302-4014.410		Quantity: 1
<b>Magnetic base 506</b> 260298-3000.128		Quantity: 1
<b>Column pin 140</b> 260297-9900.128		Quantity: 1
<b>Set of screws</b> 269302-4005.624		Quantity: 1
<b>Knurled screw 36</b> 269302-4011.325		Quantity: 2
<b>Spacing jig</b> 269302-4014.825		Quantity: 1

Fig. 3: Optical and mechanical modules and components for Focus-touching

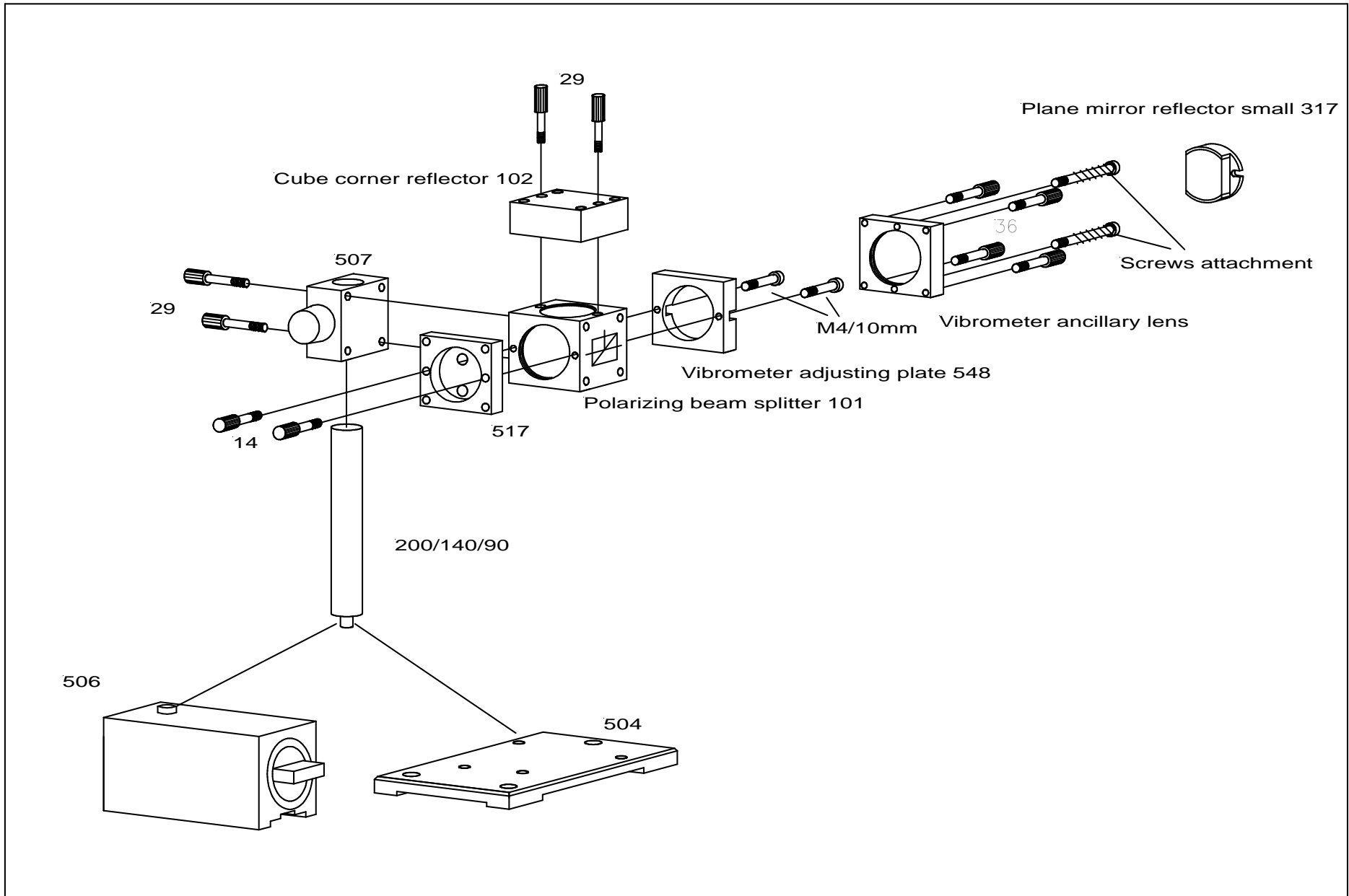


Fig. 4: Assembly of optical and mechanical components

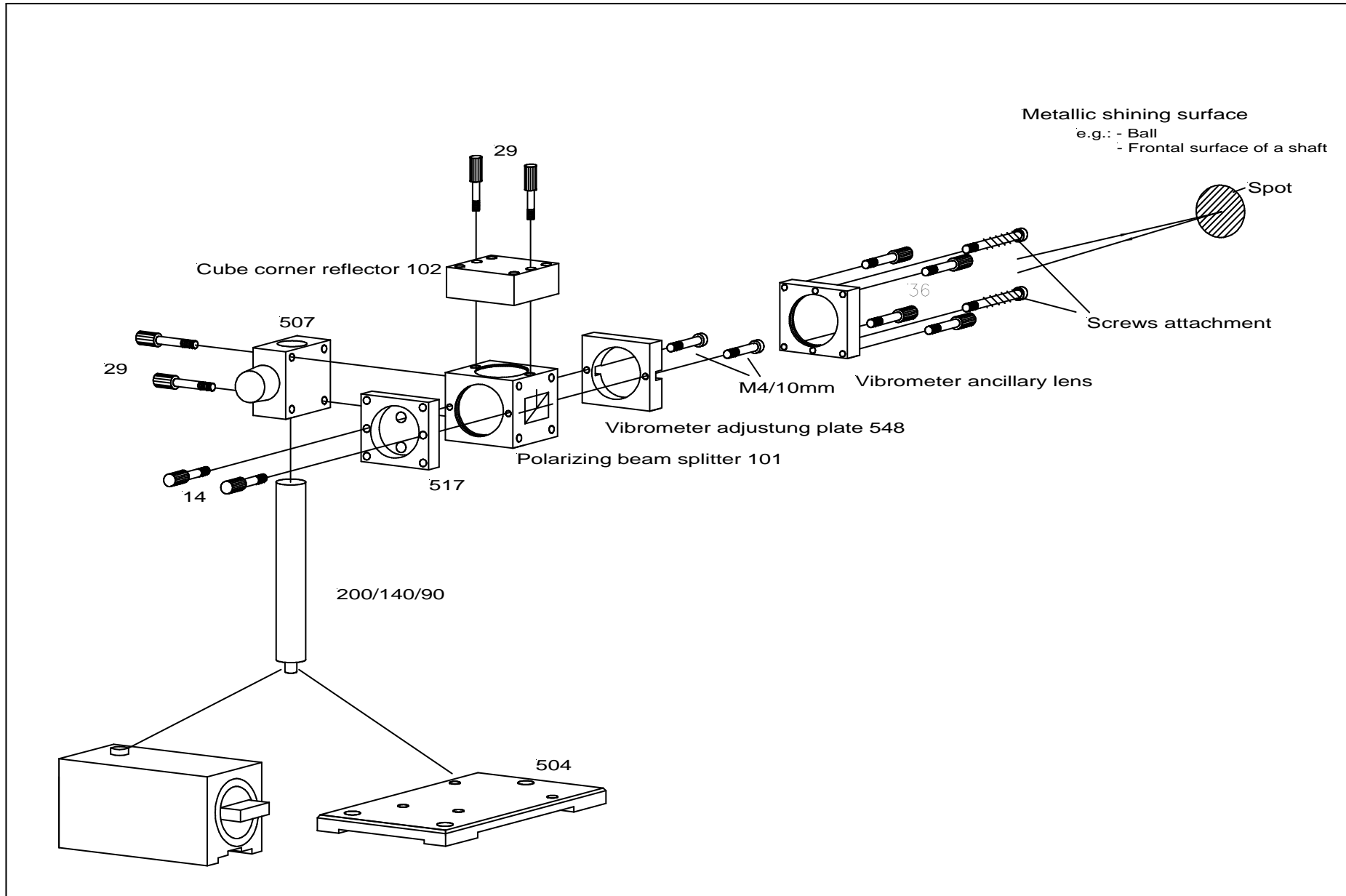
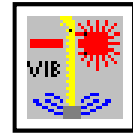


Fig. 5: Assembly of optical and mechanical components



## Interferometer for vibration measurement

### Measurement assembly

The Vibrometer ancillary lens can be fastened with the Vibrometer adjusting plate directly at the interferometer. The adjustment is carried out via four knurled screws 36. For the complete measuring mounting from **Laser measuring head - Interferometer with ancillary lens - Plane mirror reflector** should go on in following steps:

1. Identify the axis of motion to be measured and find a location on the moving part of the object where the optical system can be fixed (1).
2. Find a stationary reference point in line with the axis of movement (2).
3. Mind the focal length of the lens attachment (about 200 mm). The spacing between the lens centre and the reflecting surface should thus be  $S = 196,12$  mm.



#### Tips:

- (1) Position the laser head as closely as possible to the interferometer.
- (2) Check whether the adjustable table is at the centre of its parallel displacement and tilting ranges.  $\Rightarrow$  This is important to ensure sufficient freedom of adjustment both ways during fine alignment of the beam path.

4. Fix the optical modules at the locating points found, wherever possible, in order to reduce measurement errors:

Interferometer with ancillary lens  
Plane mirror (measuring) reflector

stationary reference point (2)  
movable reference point (1)



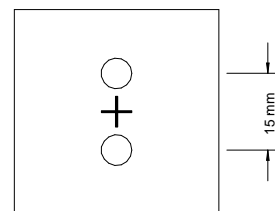
#### IMPORTANT:

The laser beam hits the reflector by 7.5 mm put to its centre.  
Only by the Vibrometer ancillary lens the beam is reflected to the centre of the reflector.

For the adjustment there are the following aids:

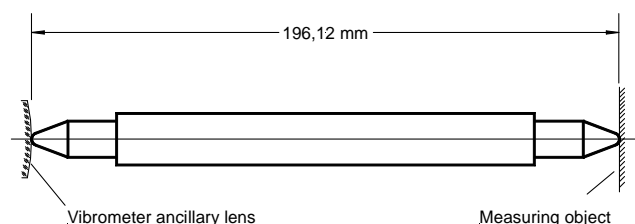
#### Target mark

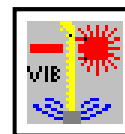
A target mark can make the adjustment easier.  
At this the cross is put to the place where the laser spot debits arrive. Ohne Vorsatzlinse wird der Laserstrahl auf den oberen Kreis ausgerichtet. Without vibrometer ancillary lens the laser beam is aligned with the upper circle.



#### Spacing jig

Serve to adjust to gap  
Measuring object - Lens top





## Interferometer for vibration measurement

---

### Adjustment

From these basic principles, the following procedure of aligning the beam path results:



- 1) Select menu item  in the "Measurement" program routine.

In this menu item, the powers of the two beams reflected back into the laser head (reference and measuring beams) are represented by two spots on the monitor screen. (With correct aligning procedure, i.e. with the interferometer removed, both the measuring and reference beams fall on the reflector.) The screen graph immediately shows the effect of alignment manipulations and thus allows the quality of alignment of the two beams to be checked and optimized. Because of the short stroke of the reflector, the screen graph does not help much for minimizing the cosine error. This should rather be attempted before, when positioning the laser head to make the beam parallel to the axis of motion. The screen graph is useful, however, for optimizing the positions of the two beams relative to the cross-hairs, i.e. making them coincide and positioning them so that they best hit the beam entrance port of the laser head.

- 2) Adjustment the distance of the Ancillary lens to the Plane mirror reflector:

The the fine adjustment between Ancillary lens – Plane mirror reflector is carried out via the 4 knurled screws against the springs of the 2 inside hexagon screws of the Vibrometer adjusting plate. To this the spacing jig can be used.

If the distance between lens and plane mirror reflector is equally the focal length of the lens, the measuring beam is represented on the screen and can be adjusted optimally to the cross-lines after this representation.



#### **IMPORTANT:**

Pay attention to the same local situation of the points of measuring and reference beam in the cross-lines.  
(importantly for perfect interferenc signal)

Aligning the interferometer completes the alignment of the setup, which is now ready for measurement (see the Software Manual).

Examples of measuring set-ups

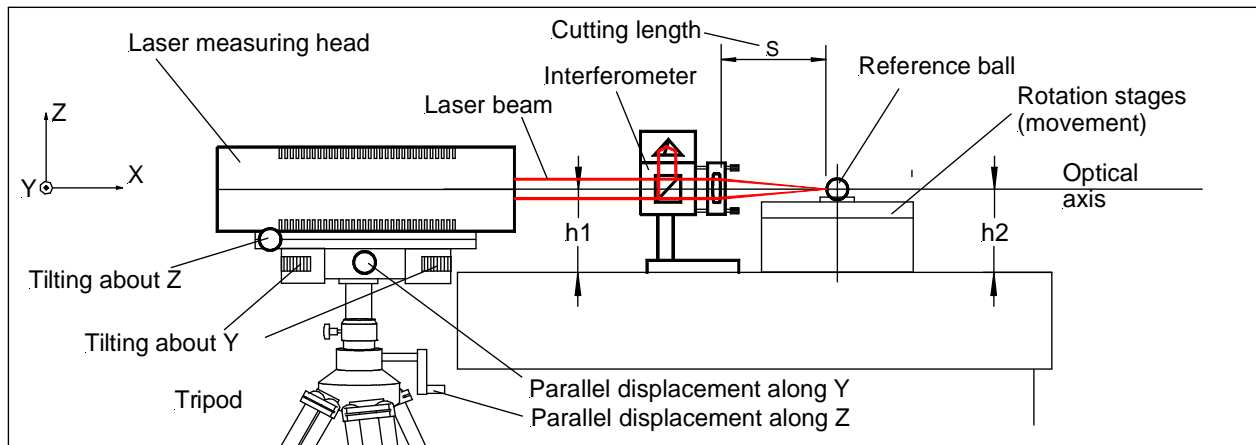


Fig. 6: Radially measurement of a rotary stage (example 1)

Explanation:

A precision glass ball with mirror coating is the reference for the measurement of the radial deviation of a rotary stage. This is centrally attached on the rotatory stage. The beam is focussed after the Ancillary lens and arrives the ball equator as a point. The beam is reflected in the same angle. Expanded by the lens the beam reaches the interferometer.

The beam axis must oriented square to the axis of rotation of the ball. The reference ball cannot be adjusted absolutely exactly to the axis of the rotatory stage. The measuring is overlaid a periodical (by 360°) sinusoidal adjustment error. This adjustment error must be eliminated by software.

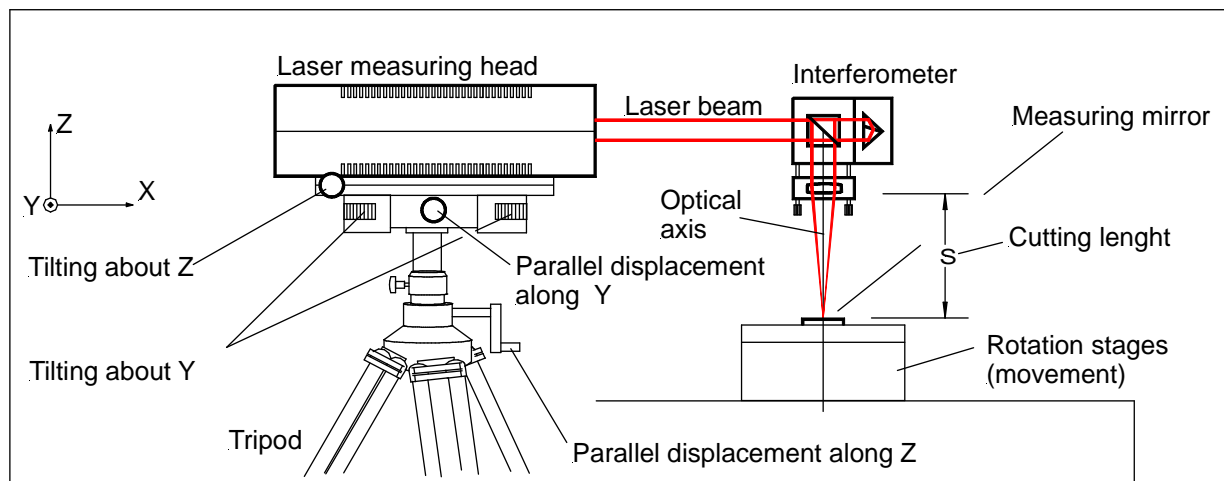


Fig. 7: axially measurement of a rotary stage (example 2)

Explanation:

A Plane mirror is attached to the measurement of the axial deviation of a rotatory stage. The unit interferometer with ancillary lens is fixed centrally. The tilting of the plane mirror to the rotary axis cannot adjust exactly. It is required to eliminate the adjustment error by a careful adjustment of the focus position on the centre of axis.